

SF - 40

Total No. of Pages :3

Seat No.	
----------	--

B.E. (Civil Engineering) (Semester - VII) (Old)

Examination, November - 2017

EARTHQUAKE ENGINEERING

Sub. Code: 47903

Day and Date :Wednesday, 15 - 11- 2017

Total Marks : 100

Time :2.30 p.m. to 5.30 p.m.

- Instructions :**
- 1) Attempt any three questions from each section.
 - 2) Figures to the right indicate full marks.
 - 3) Assume suitable data whenever necessary.
 - 4) Use of non-programmable calculator and I.S. 1893: 2002 (Part I) are allowed.

SECTION-I

- Q1) a)** What are causes of earthquake? Explain in brief plate tectonic theory. [8]
- b)** Classify and describe with suitable sketches, different types of seismic waves generated by an earthquake. [8]
- Q2) a)** Define Logarithmic decrement, how it is measured and derive the equation of Logarithmic decrement. [7]
- b)** The building frame shown in the Fig.1 is given a 100 mm lateral displacement and released from the rest to vibrate freely. Find the logarithmic decrement and displacement of the system after 12 cycles and comments on the result. Consider 10% damping. Take $EI_{\text{column}} = 1.1 \times 10^{12} \text{Nmm}$. [9]

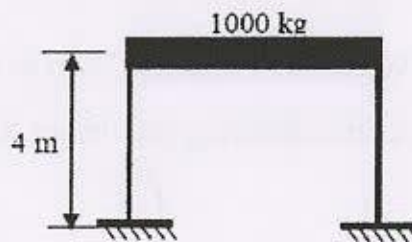

Fig. 1



P.T.O.

- Q3) a)** Explain in details Force Transmission Ratio. [05]
- b) A SDOF system consists of 5 m high column of 600 mm diameter which supports the heavy mass of 10500 kg at its top. The system is subjected to a harmonic force of $1800 \sin 50t$ N. Consider 20% damping and $E = 2 \times 10^5$. Calculate the maximum dynamic amplitude and also state whether the system will have resonance or not? [11]
- Q4)** Calculate the base shear for a five storey hospital building having special moment resisting frame (SMRF) located in Pune on medium soil with following data using seismic coefficient method. [18]
- a) No. of bay in x and y-direction = 4
 - b) Width of each bay = 5m
 - c) Thickness of slab = 150 mm
 - d) Storey height = 3.2 m
 - e) Size of beam and column = 300 mm × 450 mm
 - f) Amount of damping = 5% of critical damping
 - g) Live load = 4kN/m²

Assume any additional data if required and neglect the weight of the infill wall panels.

SECTION-II

- Q5) a)** Explain earthquake design philosophy for building. [8]
- b) Explain soft storey? Explain how soft storey problems can be eliminated in the existing buildings. [8]
- Q6) a)** Explain how "ductility of building" can be effectively designed. [8]
- b) What are the ductile detailing provisions for column? Explain with neat sketches. [8]

- Q7) a) What points should be kept in mind while designing earthquake resistant brick masonry structure? [8]
- b) Discuss in detail the advantage of horizontal bands and vertical reinforcement in the masonry buildings. [8]

Q8) Write a short note (Any three): [18].

- a) Stud Wall Construction.
- b) Strong column and weak beam.
- c) Effect of soft storey of RC structure.
- d) Jacketing of column.

EEE

SF-36

Total No. of Pages : 2

Seat No.	
----------	--

B.E. (Civil) (Semester-VII) (Revised)
Examination, November - 2017
SOLID WASTE MANAGEMENT (Elective-I)
Sub. Code : 67569

Day and Date : Thursday, 23-11-2017

Total Marks : 100

Time : 2.30 p.m. to 5.30 p.m.

- Instructions :
- 1) All questions are compulsory.
 - 2) Figures to the right indicate full marks.
 - 3) Make assumptions wherever necessary.
 - 4) Use of non-programmable calculator is allowed.

SECTION-I

Q1) Answer any two of the following: [2×8=16]

- a) What is Solid Waste and Solid Waste Management? Write the objectives of SWM.
- b) State the composition of MSW. Describe the compositions.
- c) Write note on Biomedical Waste Management.

Q2) Answer any two of the following: [2×9=18]

- a) Explain with the help of flow diagram, the functional elements of Municipal Solid Waste Management.
- b) Explain the methods of solid waste collection with a neat sketch.
- c) Explain in detail with help of figure the different types of Transfer Station.

Q3) Answer any two of the following: [2×8=16]

- a) List out the different equipment used for processing solid waste and explain any one with neat sketch.
- b) What is MRF? Explain the processes for MSW at these facilities with flow diagram.
- c) Explain with the figure the different types of air classifiers methods.

P.T.O.



SECTION-II

Q4) Answer any two of the following:

[2×9=18]

- a) What is Sanitary landfilling? Write the site selection criteria for sanitary landfilling.
- b) Draw the cross section of sanitary landfill and explain the essential components.
- c) Identify the adverse effects of a landfill leachate and its appropriate control measures.

Q5) Answer any two of the following:

[2×8=16]

- a) What is composting? Explain composting process of bio degradable MSW.
- b) Explain mechanical composting plant with flow diagram.
- c) Explain the different factors affecting composting.

Q6) Answer any two of the following:

[2×8=16]

- a) Explain the working of an incinerator with a neat sketch.
- b) Write the air pollution problem associated with incineration system and its control techniques.
- c) Describe pyrolysis and its products.



SF-38

Total No. of Pages : 2

Seat No.	
----------	--

B.E. (Civil) (Semester-VII) Examination, November - 2017
GROUND IMPROVEMENT TECHNIQUES (Elective-I)
Sub. Code : 67571

Day and Date : Thursday, 23-11-2017

Total Marks : 100

Time : 2.30 p.m. to 5.30 p.m.

- Instructions :
- 1) Que. No. 1 from section-I and Que. No. 5 from section-II are compulsory.
 - 2) Solve any two other questions from each of the section.
 - 3) Figures to the right indicates full marks.

SECTION-I

Q1) Answer the following: [4×5=20]

- a) Explain the various types of vertical drains used in ground improvement.
- b) What is mean by dynamic consolidation.
- c) Explain use of stone column as ground improvement method.
- d) Enlist various ground improvement technique according to their suitability.

Q2) a) How do vertical drains improve the functioning of pre-loading? Explain with neat sketch. [8]

b) Explain various components of ground Anchor. [7]

Q3) a) Explain design procedure of stone column. [8]

b) Explain construction sequence of soil nailing. [7]

Q4) Write a short note on [3×5]

- a) Classification of ground improvement technique
- b) Soil nailing
- c) Rock Anchor in granular soil



P.T.O.

SECTION-II

Q5) Answer the following:

[4×5=20]

- a) Enlist various factor affecting the soil stabilization.
- b) Explain the earth reinforcement mechanism.
- c) Write down the various application of earth reinforcement.
- d) Enlist different types of geosynthetics.

Q6) a) Compare and enlist the various method of soil stabilization. [8]

b) Explain the various application of geosynthetics with respect to

- i) reinforcement
 - ii) separator
 - iii) filter
 - iv) drainage
- [7]

Q7) a) Explain the stress-strain relationship of reinforced soil. [8]

b) Explain the various types of grout used in ground improvement. [7]

Q8) Write a short note on:

[5×3]

- a) Function of geosynthetics
- b) Fly-ash soil stabilization
- c) Selection of geosynthetics



Seat No.	
----------	--

B.E. (Civil) (Part - IV) (Semester - VIII)
Examination, November - 2017
DESIGN OF CONCRETE STRUCTURES - II
Sub. Code : 67748

Day and Date : Wednesday, 1 - 11 - 2017

Total Marks : 100

Time : 10.00 a.m. to 1.00 p.m.

- Instructions :
- 1) Attempt any three questions from each section.
 - 2) Figures to the right indicate full marks.
 - 3) Assume suitable data wherever necessary and mention it clearly.
 - 4) Use of non programmable calculator is allowed.
 - 5) Use of relevant IS Codes are allowed.

SECTION - I

Q1) Design rectangular beam for limit state of collapse in torsion for following data. [16]

Size of beam = 400 × 700mm, over all

Factored Shear force = 95 KN

Factored Bending moment = 180 KN.m

Factored Torsion Moment = 55 KN.m

Effective cover = 50mm

Use M20 and Fe 415

Q2) A RCC beam ABCD spanning over four supports carries a live load of 12KN/m and dead load from walls 300mm, 2.8 high. If M20 grade concrete and Fe 415 grade steel is to be used. Design the continuous beam using IS-456 - 2000 provision. Span AB = BC = CD = 6m Take unit weight brick wall 19KN/m³. Draw a sketch showing reinforcement details. [16]

Q3) Design a square water tank resting on ground having dimensions 4m × 4m and height of water is 3m. Assume free board of 0.2m. Use M20 and Fe 415 grades. [16]

P.T.O.



- Q4) a) Write a note on balanced, under reinforced and over reinforced section as per WSM. [9]
 b) Explain the concept of moment of redistribution. [9]

SECTION - II

- Q5) a) Explain in details three concepts of pre-stress concrete section in analysis. [8]
 b) Explain systems of pre-stressing with figures. [8]

- Q6) A pre-stressed concrete beam of rectangular section $300\text{mm} \times 600\text{mm}$ has a span of 10m. The effective pre-stressing force is 980KN at constant eccentricity of 120mm. The dead load of beam is 4.5KN/m and the beam has to carry a live load of 7.5KN/m [16]

Determine the extreme stresses,

- a) At the end section
 b) At the midsection without action of live load
 c) At mid section with action of live load.

- Q7) A post tensioned pre-stressed concrete beam of 16m span is subjected to an initial pre-stress of 1458KN. The profile of the cable is parabolic with the maximum eccentricity of 520mm at the center of span. [16]

$$A = 2.42 \times 10^5 \text{mm}^2, I = 5.30 \times 10^{10} \text{mm}^4, A_s = 1386 \text{mm}^2,$$

$$E_s = 2.1 \times 10^5 \text{N/mm}^2, E_c = 3.82 \times 10^4 \text{N/mm}^2$$

$$\mu = 0.25, k = 0.0015/\text{m}, \text{anchorage slip} = 2.5\text{mm}, \text{creep coefficient} = 1.5, \alpha = 0.13$$

Determine the following losses in pre-stress,

- a) Elastic shortening.
 b) Shrinkage in concrete.
 c) Creep in concrete.
 d) Slip in anchorage.
 e) Frictional loss.

Q8) Design a pre-tensioned concrete rectangular section for the following details

Effective span of beam = 12m.

Live load of intensity = 30 KN/m.

Concrete grade = M 35

Ultimate stresses tendon = 1450 N/mm²

Loss of pre-stress = 20%

Assume Safe stress is 0.6 times Ultimate stress in tendon.

Permissible stress in concrete at transfer stage is $0.5 \sigma_{ck}$

Permissible stress in concrete at working stage is $0.4 \sigma_{ck}$

Permissible tensile stress in concrete at transfer and working stage is 1.2 N/mm²

[18]



Seat No.	
----------	--

B.E. (Civil Engineering) (Semester - VIII)
Examination, November - 2017
STRUCTURAL DESIGN OF FOUNDATION AND
RETAINING STRUCTURES (Elective - II)
Sub. Code: 67753

Day and Date :Monday, 06 - 11- 2017
 Time :10.00 a.m. to 1.00 p.m.

Total Marks : 100

- Instructions :
- 1) Solve any two questions from each section.
 - 2) Figures to the right indicate full marks.
 - 3) Use of IS 456- 2000 is allowed.
 - 4) Assume suitable data if necessary and mention it clearly.
 - 5) Use of non-programmable calculator is allowed.

SECTION-I

- Q1)** Two columns A and B 5 m apart between centres carry loads 840 kN and 1200 kN. Design a 2 m wide combined rectangular footing for the columns. The footing shall consist of a central longitudinal beam with cantilevering slabs on either side. Each column is 400 mm × 400mm. The safe bearing capacity of soil is 150 kN/m². Use M 20 grade concrete and Fe 415 steel. [25]
- Q2)** A column carrying a load of 2500 kN has to be supported on 4 piles each of size 300 mm × 300 mm. The piles are spaced at 1.00 m centres as shown in figure.1. The column size is 600 mm × 600 mm. Design the pile cap. Use M 20 grade concrete and Fe 415 steel. [25]

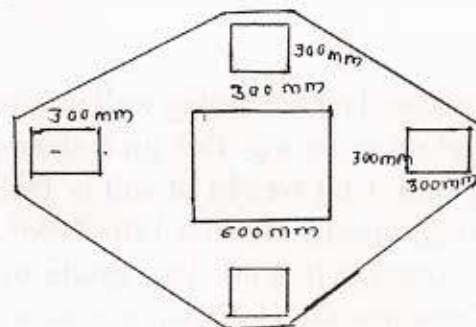

Fig. 1



P.T.O.

Q3) Design a suitable continuous raft foundation connecting the columns of a building $12\text{ m} \times 12\text{ m}$ shown in figure to suit the following data. [25]

- Spacing of column = 4 m C/C
- Service load transmitted = 500 kN on each column.
- Size of column = $300\text{ mm} \times 300\text{ mm}$.
- Safe bearing capacity = 150 kN/m^2 .
- M 20 concrete and Fe 415 steel.

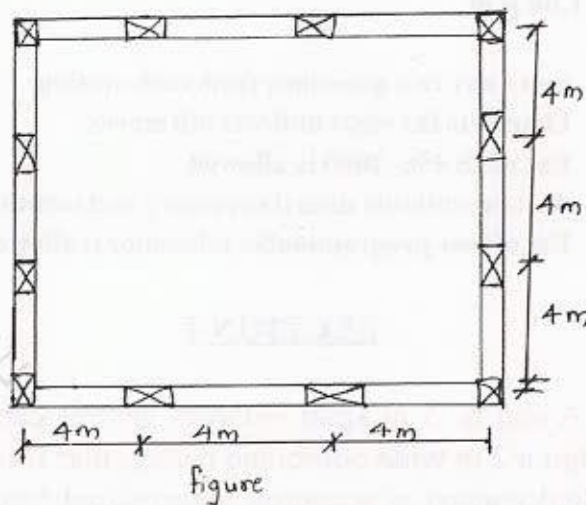

SECTION-II

Q4) a) Draw neat sketch of well foundation and explain function of each component part in detail. [12]

b) Enlist different types of well foundation explain each in detail with neat sketch. [13]

Q5) A stem of cantilever retaining wall is 3.8 m tall, The cantilever retaining wall retains soil up to its top. Design a stem, toe and heel slab of a cantilever retaining wall. Unit weight of soil is 19 kN/m^3 . The angle of repose is 30° . Safe bearing capacity of soil is 180 kN/m^2 . The coefficient of friction between soil and concrete is 0.60 . Use grade of concrete M_{20} and grade of steel Fe 415. Draw neat sketch showing reinforcement details of cantilever retaining wall. [25]

- Q6) a) Explain breakwater and its application? Draw a neat sketch and explain vertical wall break water. [12]
- b) Design armor of rubble mound breakwater if depth of water is 17.0m. Wind velocity is 165Km/Hour. Fetch of wave is 260KM. Allowable bearing pressure on rock is 800KN/M². [13]

EEE

- b) Differentiate between free hold property and lease hold property. [5]
- c) Write the significance of sinking fund and derive its expression. [5]

Q8) Write short note on (any three): [18]

- a) Building lease and occupational lease.
- b) Valuer and his duties.
- c) Different types of values.
- d) Arbitration.

EEE

Seat No.	
----------	--

B.E. (Civil) (Semester - VII) (New Course)
Examination, November - 2017
QUANTITY SURVEYING & VALUATION
Sub. Code: 67560

Day and Date : Wednesday, 15 - 11 - 2017
 Time : 2.30 p.m. to 6.30 p.m.

Total Marks : 100

- Instructions :
- 1) Q.No. 1 is compulsory.
 - 2) Attempt any two questions from remaining questions of section I.
 - 3) Attempt any three questions from section II.
 - 4) Assume any other additional data if required and state it clearly.

SECTION-I

Q1) Work out the quantities of below retaining wall 50m in length as stated. [20]

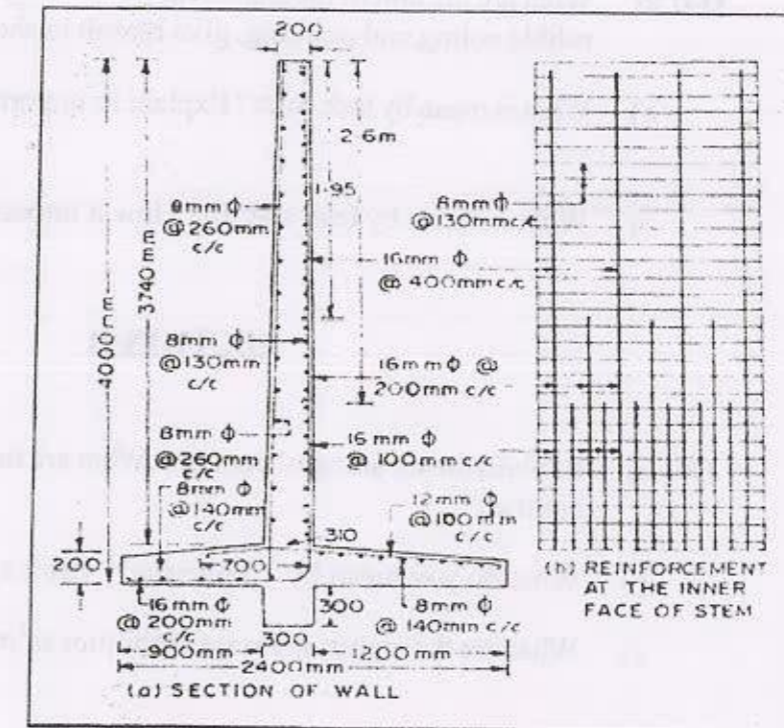

P.T.O.



- a) Calculate concrete quantity in standard format.
b) Prepare a BBS of given figure in standard format.

- Q2) a) Write different types of estimate and state various items to be included in it. [5]
b) What is DSR? Prepare analysis of rate for a RCC isolated box footing of area 2.5Sq.M, and 3.1Sq.M each for a concrete depth 350mm. [10]

- Q3) a) Which are the various extra charges taken in to account for preparing detailed estimate and why? Explain in detail. [8]
b) Write unit of measurement of any three civil engineering items. Write mode of measurement for excavation and concrete. [7]

- Q4) a) What are the unit of measurement for skirting, door handle, steel sections, rubble soling and pointing, give reason in short. [5]
b) What is mean by task work? Explain its importance with suitable example. [5]
c) What is mean by lead and lift? How it impacts the cost? [5]

SECTION-II

- Q5) a) Explain the meaning of contract. What are the reasons of for rejection of contract? [7]
b) What do you mean by "Tendering"? Draft a sample tender notice. [5]
c) What are the rights and responsibilities of parties of contract. [5]

- Q6) a) Explain valuation by development method. [6]
b) A plot shown in figure is to be valued according to the following details: [10]
i) Front width is 50m
ii) Rear width is 75m
iii) Initial depth is 20m
iv) Market rate of land in the same locality is Rs. 375psm.

Use belting method of valuation.

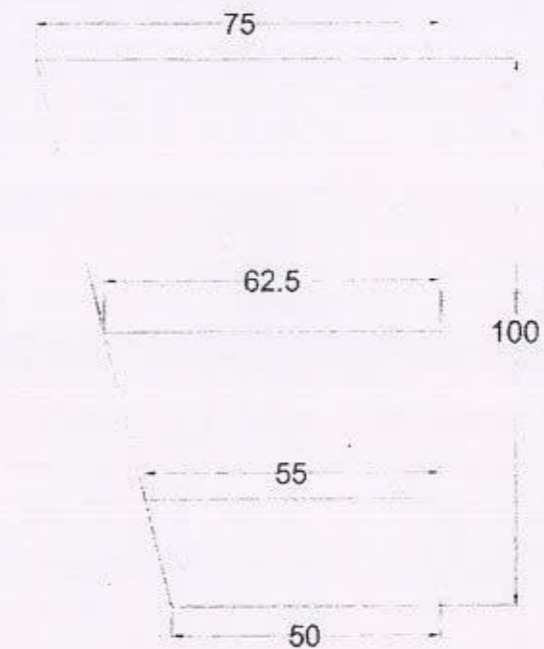

- Q7) a) A plate compactor was purchased at Rs. 80,000/-. Assume salvage value to be 10% after 8 years, Calculate depreciation for every year by following methods: [6]
i) Straight line method
ii) Constant percentage method.

Seat No.	
----------	--

B.E. (Civil) (Semester-VII) (Revised) Examination, November - 2017
PROJECT MANAGEMENT AND CONSTRUCTION EQUIPMENT
Sub. Code : 67561

Day and Date : Tuesday, 21 - 11 - 2017

Total Marks : 100

Time : 2.30 p.m. to 5.30 p.m.

- Instructions : 1) Attempt any THREE questions from each Section.
 2) Figures to the right indicate full marks.

SECTION-I

- Q1) a) Explain the role of various agencies involved in a construction project. [8]
 b) A project consists of following activities with their duration in days. [9]

Activity	1-2	1-3	1-4	2-5	3-6	4-5	4-6	4-7	5-7	6-7
Duration (days)	6	3	4	0	4	12	10	8	5	6

Draw the network. Find out critical path and project duration.

Following conditions exists at the end of 10th day,

- Activities 1-2, 1-3, 1-4 have been completed as per schedule.
- Activities 4-5, 4-6, 3-6 are in progress and will require 6,6 and 1 more days for its completion, respectively.
- Other activities have not been started and their duration holds good except activity 5-7 which will require only 3 days instead of 5 days as planned originally.

Update the network.



P.T.O.

- 2) a) Explain the concept of Normal and Beta Distribution in P.E.R.T. [8]
- b) With the information given in the table draw the network for a construction project. Determine the critical path and its standard deviation. Find Probability of completion of project in 40 days. (For $Z = 1.7$, Pr. = 95.54%; For $Z = 1.8$, Pr. = 96.41%) [9]

Activity	Optimistic time	Most likely time	Pessimistic time
1-2	2	5	8
2-3	8	11	20
3-4	0	0	0
2-4	4	7	16
2-5	4	9	20
4-6	7	10	13
5-6	3	7	17
3-7	3	5	13
6-7	2	3	10
7-8	2	4	6

- 3) a) Explain various safety equipment used on construction sites. [8]
- b) What are the common risks on construction projects? How will you identify these risks? [9]

- 4) Write notes on any FOUR. [16]
- Objectives of Project Management.
 - Milestone Chart.
 - Resource Allocation.
 - Safety Policy.
 - Safety Training.

SECTION-II

- 5) a) Explain the construction and operation of Bulldozer with neat sketch. [8]
- b) Explain working of Scraper with neat sketch. [8]
- 6) a) Explain the construction and working of 'Clamshell'. [8]
- b) Enlist various types of compacting equipment. Explain any ONE with sketch. [9]
- 7) a) Explain the 'safety measures' in blasting operations. [8]
- b) Explain in detail 'Well Point System' of dewatering with neat sketches. [9]
- 8) Write notes on any FOUR. [16]
- Mechanical v/s Manual Construction.
 - Use of Tractors in construction.
 - Tippers.
 - Detonators.
 - Necessity of drainage in excavations.

* * *

Seat
No.

B.E. (Civil Engineering) (Semester - VII)

Examination, November - 2017

EARTHQUAKE ENGINEERING (New)

Sub. Code : 67559

Day and Date : Monday, 13-11-2017

Total Marks : 100

Time : 2.30 p.m. to 5.30 p.m.

- Instructions :
- 1) Figures to the right indicate full marks.
 - 2) Assume any suitable data whenever necessary.
 - 3) Use of non-programmable calculator and I.S. 1893: 2002 (Part I) are allowed.

SECTION - I

- Q1) a) What is mean by plate boundaries? Explain in details. [8]
 b) Classify ad describe with suitable sketches, different types of waves generated by an earthquake? [8]
- Q2) a) Derive the equation of motion and its solution for free damped vibration system. [8]
 b) Find the natural frequency and natural period for the building frame shown in the fig. 1. During test the frame is given 40 mm initial lateral displacement and released from the rest to vibrate freely. Find the displacement after 4 seconds and number of cycles when amplitude reduced to 1/20 of maximum. Consider 10% damping. Take $EI_{\text{Column}} = 1.5 \times 10^{12} \text{ N.mm}^2$, $EI_{\text{Beam}} = \infty$. [10]

OR

- b) A SDOF system consists of 5 m high column of 450 mm diameter which supports the heavy mass of 20 tonne at its top. The system is subjected to a harmonic force of $200 \sin 40t$ kN. Consider 20% damping & $E = 2.1 \times 10^5 \text{ N/mm}^2$. Calculate the maximum dynamic amplitude. Also, state whether system will have resonance or not? [10]

P.T.O.



Q3) Calculate base shear in the critical direction only for BSNL office in Pune with following data by seismic coefficient method. [16]

- No. of storey = 4
- No. of bay in x direction = 3
- No. of bay in y direction = 1
- storey height = 3 m
- Width of each bay = 5 m
- Total DL on roof = 12 kN/m^2
- Total DL on floor = 10 kN/m^2
- LL = 4 kN/m^2 ,
- Thickness of slab = 120 mm

All columns having their longer side in X direction. Neglect weight of infill walls. Assume suitable data if required. Write all your assumptions & clauses of IS 1893 (2002). Building is provided with additional viscous dampers which will increase damping by 10%.

SECTION - II

- Explain ductile detailing of beam as per IS 13920: 1993. Also give limitation of this code. [10]
- Explain four virtue of good earthquake resistant design. [8]

OR

- Explain soft storey & discuss its performance of soft storey building in past earthquakes. How will you avoid soft storey? [8]

Q5) a) Define the shear wall and its classification? Describe the structural behavior of shear wall? [8]

- Draw the detailed sketch of
 - Different ways of beam jacketing as IS code and.
 - Different ways of columns as per IS code.

Q6) a) Explain in details concept of Friction Pendulum Bearings? [8]

- Explain Tuned Liquid Dampers with its working principal? [8]

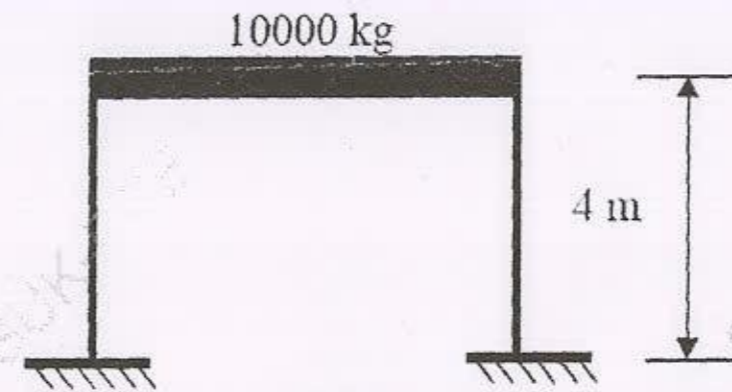

Fig 1.



Seat No.	
----------	--

T.E. (Civil) (Semester - VI) (Revised)
Examination, November - 2017
GEOTECHNICAL ENGINEERING - II
Sub. Code: 66874

Day and Date :Thursday, 02 - 11 - 2017

Total Marks : 100

Time :2.30 p.m. to 5.30 p.m.

- Instructions :**
- 1) All questions are compulsory.
 - 2) Figures to the right indicate full marks.
 - 3) Make assumptions wherever necessary.
 - 4) Use of non-programmable calculator is allowed.

SECTION-I

Q1) Solve any three from following. [18]

- a) Explain bore hole logging with sketch for soil and rock exploration.
- b) List engineering properties of rock. Explain any one with method for determination.
- c) Explain elastic settlement of shallow foundation.
- d) List types of bearing capacity failure of soil. Explain any one with sketch.

Q2) Solve any two from following. [16]

- a) Explain standard penetration test for determination of bearing capacity.
- b) A plate load test was carried out on a ground having uniform sand strata up to sufficient depth. The size of the plate used was 30cm×30cm. Determine the bearing capacity and load that can be taken by a column foundation of size 1.2 m× 1.2 m in the above strata for an allowable settlement of 2 cm.

Load(kN)	4.5	9	18	27	36	45	54
Settlement (mm)	0.75	1.25	2.0	3.5	5.38	7.75	10.75

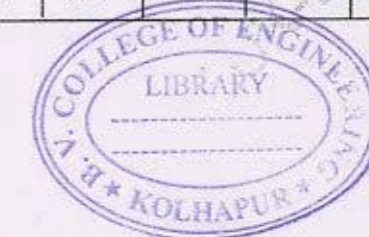

P.T.O.

SF - 23

- c) Write and explain equation of net ultimate bearing capacity of soil for general shear failure by IS code method with shape, depth, inclination of load and water table factor.

13) Solve any two from following. [16]

- a) Explain stepwise procedure for design of strap foundation with required equations and sketch.
 b) Design a trapezoidal combined foundation for following data:

Column	Size	Load	Remark
A	0.50×0.50 m	2000kN	Column A is on boundary of plot. C/c distance between columns is 5.0 m. Safe bearing capacity of soil is 200kN/m ²
B	0.30×0.30m	1500kN	

- c) A rectangular foundation of 6.0 m × 4.0 m size carries a uniform load intensity 160kN/sq.m and is located at a depth of 1.5 m in a layer of clay having $E=4 \times 10^4$ kN/sq.m and Poisson's ratio as 0.38. This clay layer underlain by second layer of silty soil having $E=7 \times 10^4$ kN/sq.m and Poisson's ratio as 0.48. A hard strata lies below the second layer. Determine the elastic immediate settlement of the foundation.

SECTION-II

14) Solve any three from following: [18]

- a) What is group efficiency of pile group? Explain Feld's rule.
 b) Explain with neat sketch under reamed pile and their uses.
 c) A rectangular pile of section 0.60 m × 0.75 m and length 12 m penetrates a deposit of clay with $c=42$ kN/m². Assuming $m=0.75$, determine the magnitude of negative skin friction.

SF - 23

- d) Find the allowable bearing capacity of a single pile in the group of piles given below, by using: Converse-Labarre Formula. Given data:- Diameter: 400mm, $C_u=50$ kPa, $\gamma=18$ kN/m³ F.S.=2.5

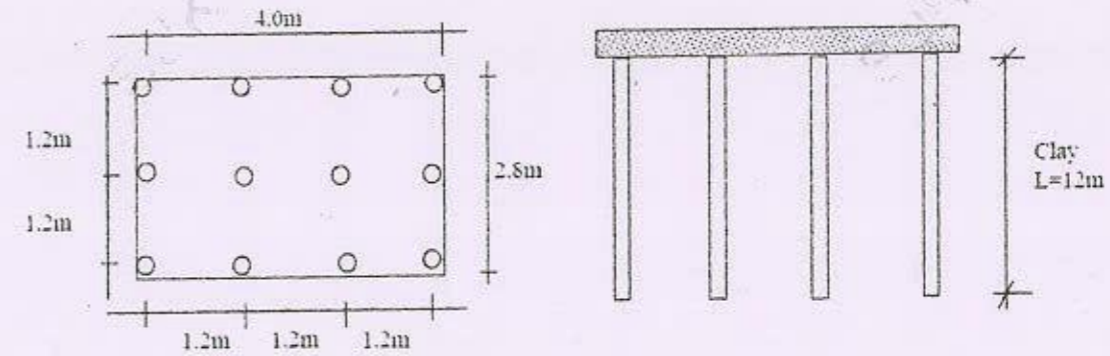

15) Solve any two from following: [16]

- a) Describe the methods of rectifying the tilt in the well during sinking operation.
 b) Explain with fig. sand island method.
 c) Write the different types and material used for sheet pile.

16) Solve any two from following: [16]

- a) Explain the friction circle method of slope stability analysis.
 b) Name the techniques used in ground improvement and explain any one.
 c) A slope 1 in 2 with a height of 8 m has the following properties of soil are $C_u = 28$ kN/m², angle of internal friction = 10° and unit weight of soil is 18 kN/m³, Stability Number = 0.064. Calculate factor of safety with respect to cohesion. What will be critical height of the slope in this soil?



Seat No.	
----------	--

T.E. (Civil) (Semester - VI) (Revised)
Examination, November - 2017
THEORY OF STRUCTURES
Sub. Code: 66873

Day and Date : Wednesday, 01 - 11 - 2017
 Time : 2.30 p.m. to 5.30 p.m.

Total Marks : 100

- Instructions :**
- 1) All questions are compulsory.
 - 2) Figures to the right indicate full marks.
 - 3) Use of non-programmable calculator is allowed.
 - 4) Assume suitable data if necessary.

SECTION-I

- Q1) a)** Explain in brief 'Static Indeterminacy of Structures'. [5]
- b) Analyze the propped cantilever beam AB of 5m span, fixed at A and propped at B when subjected to a point load of 5kN at 3m from left end A. Take fixed end moment ' M_A ' as a redundant. Also draw SFD and BMD. [12]

OR

A fixed beam AB 5m in span is subjected to a point load 5kN at 3m from left end A. Analyze the beam by taking ' R_B ' and ' M_B ' as redundants. Draw SFD and BMD.

- Q2) a)** Explain 'Unit load Method' to find slope and deflections in structural members. [5]



P.T.O.

- b) The bent ABC is subjected to lateral load of 10kN as shown in the fig.1 below. Determine the reactions at support C by strain energy method. Draw SFD and BMD [12]

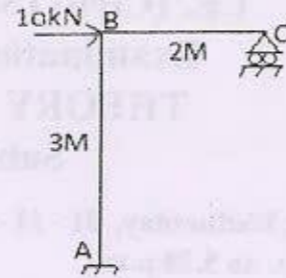

(FIG.1)

- 3) A continuous beam ABCD is fixed at A and simply supported at B and C with CD as a overhang wherein AB=4m BC=3m and CD=2m. The span AB is subjected to a udl of 10kN/m throughout, span BC to a point load of 25kN at its midpoint and point D is acted upon by a clockwise couple of 50kNm. During loading support C settles by 5mm. Draw SFD and BMD. Take $EI_{BC} = 2 \times 10^4 \text{ kN/m}^2$. $EI_{AB} = 2EI_{BC}$. [16]

SECTION-II

- 4) A two span continuous beam ABC has span AB of 6 m and Span BC of 4 m. End A is fixed while end C of the beam is simply supported. Span AB carries through u.d.l of 20 KN/m and BC carries central point load 40kN.Span AB has its inertia double that of span BC. Analyse the beam using slope deflection method. Draw SFD and BMD. [17]
- 5) Analysis the continuous beam loaded as shown in fig.by method of moment Distribution method. Sketch the BMD and SFD. [17]

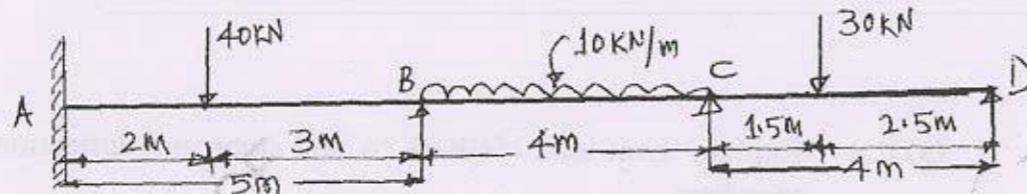

- 6) Analysis the two span continuous beam as shown in fig. by stiffness matrix method. Also draw BMD. [16]

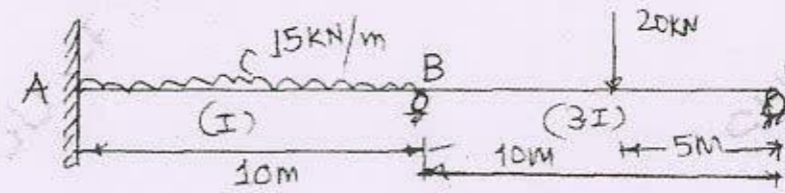

OR

- Analysis the continuous beam as shown in fig.by flexibility matrix method. Take EI constant throughout. [16]

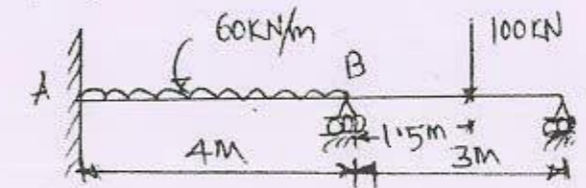

Seat No.	
----------	--

T.E. (Civil) (Semester - V) (Revised)
Examination, November - 2017
GEOTECHNICAL ENGINEERING - I
Sub. Code: 66238

Day and Date :Monday, 20 - 11 - 2017

Total Marks : 100

Time :10.00 a.m. to 1.00 p.m.

- Instruction :**
- 1) All questions are compulsory.
 - 2) Figures to the right indicate full marks.
 - 3) Make assumptions wherever necessary.
 - 4) Use of non-programmable calculator is allowed.

SECTION-I

Q1) Answer any three of the following.

[18]

- a) Derive the relation for bulk unit weight of soil in terms of Sp. Gravity, water content, void ratio of soil and unit weight of water.
- b) List and explain corrections applied to hydrometer reading in wet mechanical analysis.
- c) Explain soil structures according to structural composition of sedimented soil.
- d) A soil has a dry density of 1.72 gm/cc in the natural condition. When the 840 gm of the dry soil was poured in a container in a loose state its volume was 602 cc. The same soil when vibrated and compacted was found to have volume of 440 cc. Determine relative density of the soil.

Q2) Answer any two of the following.

[16]

- a) Explain Darcy's law and its validity used for permeability of soil.
- b) Explain flow net. Derive Laplace equation in two dimensional flow used for flow net construction.

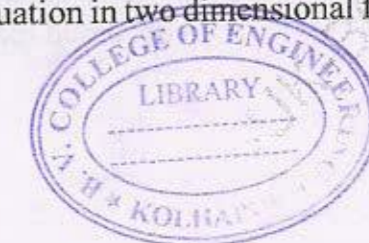

P.T.O.

- c) The results of constant head permeability test on soil are follows:-

Internal diameter of permeameter - 7.5 cm.

Head lost over a soil sample length of 18 cm- 24.7 cm

Quantity of water collected in 60 seconds - 626 cc

Porosity of the soil sample - 44%

Determine the coefficient of permeability of soil and also discharge velocity and seepage velocity during the test.

- 3) Answer any two of the following. [16]

- a) List laboratory methods for determination of compaction factors. Explain any one.
- b) Explain fixed ring type consolidometer test for determination of compressibility characteristics of soil with neat sketch.
- c) The following are the results of the standard Proctor compaction test.

Mass of mould and compacted soil (gm)	2925	3095	3150	3125	3070
Water content (%)	10.0	12.0	14.3	16.1	18.2

Volume of mould - 1000 cc, Mass of mould - 1000 gm,

Sp. Gravity of soil solids - 2.70

Plot the compaction curve showing OMC and MDD. Determine the degree of saturation at MDD.

SECTION-II

- 4) Answer any three of the following. [18]

- a) With a neat sketch explain pressure bulb and its significance.
- b) Write a note on Newmark's chart.
- c) Prove that maximum vertical stress on a plane at a distance 'r' from concerned load Q acting at ground surface will be at a depth $z = 1.225r$.

- d) A water tank is supported by a ring foundation having outer diameter of 8 m and inner diameter of 6m. The uniform load intensity on the foundation is 300 kN/m^2 . Compute the vertical stress caused by the water tank at a depth of 4 m below the center of the foundation.

- 5) Answer any two of the following. [16]

- a) Explain unconfined compression test procedure with neat sketches.
- b) An unconfined cylindrical specimen of clay fails under an axial stress of 240 kN/m^2 . The failure plane was inclined at an angle of 55° to the horizontal. Determine the shear strength parameters of the soil.

- c) The results of two drained triaxial tests on a saturated clay follows:-

Specimen I :- $\sigma_3 = 70 \text{ kN/m}^2$ and $\sigma_d = 130 \text{ kN/m}^2$

Specimen II :- $\sigma_3 = 160 \text{ kN/m}^2$ and $\sigma_d = 223.5 \text{ kN/m}^2$

Determine the shear strength parameters. Solved by analytical method.

- 6) Answer any two of the following. [16]

- a) Derive an expression for Rankine's active earth pressure due to submerged cohesionless backfill with neat sketch.
- b) A cantilever retaining wall of 7 m high retains sand. The properties of the sand are $e = 0.5$, $\phi = 30^\circ$, and $G = 2.7$. Using Rankine's theory determine the active earth pressure at the base when the backfill is

- i) dry
ii) saturated and
iii) submerged.

- c) A retaining wall 6 m high retains a clay backfill with $c = 20 \text{ kN/m}^2$, $\phi = 15^\circ$ and $\gamma = 18 \text{ kN/m}^3$. Assume that the wall is smooth and the back vertical. It is expected that tension cracks may develop to the full theoretical depth. Calculate the total active earth force acting on the wall.



Seat No.	
----------	--

T.E. (Civil) (Semester - V) (Revised)
Examination, November - 2017
ENVIRONMENTAL ENGINEERING - I
Sub. Code :66237

Day and Date : Tuesday, 14- 11 - 2017

Total Marks : 100

Time : 10.00 a.m. to 1.00 p.m.

- Instructions :
- 1) All questions are compulsory.
 - 2) Assume and mention data if necessary.

Q1) Answer Any Three of following. [3 × 6 = 18]

- a) Explain the basis on which the water source is selected for water supply.
- b) 'Water should be necessarily treated before municipal supply.' Explain.
- c) State details of intake well from its place and importance point of view.
- d) Explain design steps for intake well.
- e) Write a note on Population Forecasting.

Q2) a) Design a cascade aerator for 10 MLD flow. [8]

- b) Explain the concept of destabilization of colloidal particles during coagulation. [4]
- c) Explain the concept of tube & plate settler. [4]

Q3) a) What is demineralization? Explain any one process in detail. [6]

- b) Explain detailed operation of filtration process in rapid sand filter with diagram. [6]

OR

- b) Explain water softening process. Explain any one in detail. [6]
- c) Explain forms of chlorination. [4]

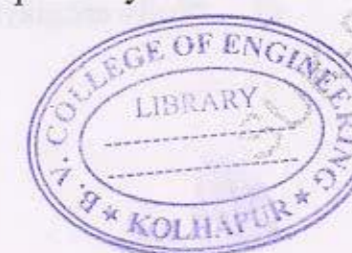

P.T.O.

SECTION - II

Q4) Answer any three of following. [3 × 6 = 18]

- a) Explain details of steel pipes with respect to strength, durability, leakage, laying, transportation, availability and advantages.
- b) Mention necessity and types of reservoirs in detail.
- c) Write a note on
 - i) Pumping mains
 - ii) Gravity mains
- d) Explain the pressure testing process in detail.
- e) Explain factors considered for choice of pipe materials.

Q5) a) What are the various layout patterns of water distribution system? [5]

b) A pipe network consist of following pipes- [8]

Pipe	Length(m)	Dia(mm)	Friction factor
AB	400	300	0.014
BC	600	300	0.010
AD	500	400	0.012
DC	500	250	0.011

Inflow at A is 1 m³/s, while outflow at B,C and D are 0.3, 0.5 and 0.2 m³/s respectively. Find flow in pipes.

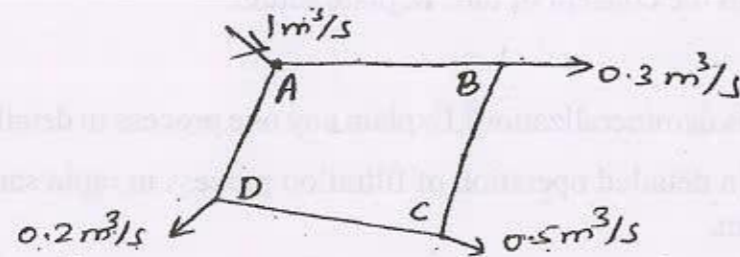

c) "Software plays a vital role in network analysis." Explain. [3]

Q6) a) Explain fire hydrants and water meter in detail. [6]

b) Explain the maintenance of water distribution system. [6]

OR

b) Write a note on green building materials. [6]

c) What is water budgeting? [4]

★ ★ ★

SF - 1008

Total No. of Pages : 3

Seat No.	
----------	--

T.E. (Civil) (Semester - V) Examination, November - 2017

DESIGN OF STEEL STRUCTURES (New)

Sub. Code : 66236

Day and Date : Saturday, 11 - 11 - 2017

Total Marks : 100

Time : 10.00 a.m. to 01.00 p.m.

- Instructions :
- 1) All questions Compulsory.
 - 2) Use of IS 800:2007, IS 875, Steel table, Non programmable calculator permitted.
 - 3) Figure to the right indicate full marks.
 - 4) Draw sketches wherever necessary.
 - 5) Assume suitable data if required.

SECTION - I

- Q1) a) What is serviceability Limit state? Explain. [4]
b) Write note on "High Strength Friction Grip (HSFG) bolts." [4]
c) A tension member is subjected to force of 150 KN. The member consists of a plate 75mm × 8mm in size is connected to 10mm thick gusset plate. The grade of steel is Fe 410. Design fillet weld if (a) Weld is provided on two sides of plate in direction of force. (b) Weld is provided on three sides of plate. [8]
- Q2) a) Explain in brief with sketches the modes of failure of tension members. [6]
b) A tension member of a truss consist of two angles 75×50×6 which are provided on either side of a 10mm thick gusset plate. 20mm dia. Bolts are used in one row for connecting the member to the gusset plate. Determine design tensile strength of the member and also the number of bolts required to develop the design tensile strength. [12]

OR

- b) Design an angle section to carry a factored tensile force of 200 kN. Bolts of 20mm diameter are to be provided for the connection of the member to the gusset plate. Take $f_y = 250\text{Mpa}$ and $f_u = 410\text{Mpa}$. [12]

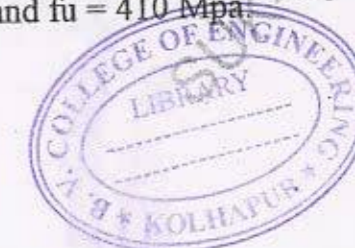

P.T.O.

- 23) a) Explain the terms with reference to compression members, (i) Effective length of struts, (ii) Slenderness ratio. [4]
- b) Two angles $90 \times 60 \times 8$ are used as strut 3m long and connected to 10mm thick gusset plate at each end. Determine the design strength of the strut for the following cases. [12]
- When the longer leg of the angle are connected on either side of gusset plate.
 - When the longer leg of the angle are connected to same side of gusset plate

SECTION - II

- 24) a) Why lacing is provided for column? How much load is taken by lacing. [4]
- b) Design a 8m long built up column to carry a factored axial load of 1250 KN. The column is restrained in position but not direction at each end. The column shall consist of two channels placed toe to toe at a suitable spacing. [12]

OR

- b) An ISHB400 @759.3 N/m column carries a factored axial load of 2000 KN. Design a slab base for the column. Assume that the bearing surfaces of the column and base plate are machined. The concrete footing is of M20 grade. [12]

- 25) a) What is web buckling and web crippling? How the beam checked against web buckling and crippling? [6]
- b) A 150mm thick slab is supported on steel beams of effective span 5.25m which are spaced at 3.25m c/c. Allow live load of 3.50 kN/m^2 and a 40mm floor finish at 20 kN/m^3 . Design the beam and check it for shear. [12]

- 26) a) Draw neat sketch of (i) crane gantry girder assembly (ii) the typical cross sections for gantry girder. [4]

- b) The Crane system has the following data. Determine the design forces acting on it. [12]
- Crane capacity = 100kN
 - Weight of crane girder = 90kN
 - Weight of crab, motor, hook = 20kN
 - Minimum hook Approach = 1.1 m
 - Wheel base = 2.5 m
 - Span of gantry girder = 5.5 m
 - Weight of gantry girder = 8 kN
 - c/c spacing of crane rails = 20 m
- The crane is electrically operated.



Seat No.	
----------	--

T.E. (Civil) (Semester-V) (Revised)
Examination, November - 2017
WATER RESOURCES ENGINEERING - I
Sub. Code : 66235

Day and Date : Thursday, 09-11-2017

Total Marks : 100

Time : 10.0 a.m. to 1.00 p.m.

- Instructions :
- 1) Que. 1 and 5 are Compulsory. Attempt any two questions from remaining questions from both sections.
 - 2) Assume any suitable data if necessary, wherever needed.
 - 3) Figures to the right indicate full marks.

SECTION-I

- Q1) a)** Explain infiltration capacity of the soil with help of a graph. Explain the effects of infiltration. [6]
- b) Describe the procedure to construct unit hydrograph from storm hydrograph. [6]
- c) Explain how discharge of the water stream is measured? Explain any one method in detail. [6]
- Q2) a)** Exnlist different methods of assessment of average precipitation. Explain any one method in detail with a neat sketch. [8]
- b) Define evaporation process. Describe the factors affecting evaporation and also the measures to reduce it. [8]
- Q3) a)** Define unit hydrograph. List the assumptions and limitations involved in unit hydrograph theory. [8]
- b) Given below are the ordinates of 4 hour unit hydrograph. Derive and plot 16 hour unit hydrograph. Describe the procedure in detail. [8]

Time(hours)	0	4	8	12	16	20	24	28	32	36	40
Observed flow(m ³)	0	16	58	89	145	80	55	36	16	8	0



P.T.O.

SF-19
[16]

Q4) Write detailed notes on:

- Abstract losses from precipitation
- Factors affecting runoff
- Site selection criteria for discharge measurement of river.
- Flood frequency analysis

SECTION-II

- Q5) a) Define porosity, specific yield and specific retention and obtain relation between them. [6]
- b) The base period, intensity of irrigation and duty of water for various crops under a canal system are given below. Determine the reservoir capacity if culturable commanded area is 40000 hectors, canal losses are 20% and reservoir losses are 10%. [6]

Crop	Base period (Days)	Duty of water at the field (Hectors/ cumec)	Intensity of irrigation (Percentage)
Cotton	180	1400	10
Sugar cane	360	1700	20
Wheat	120	1800	20
Rice	120	800	15
Vegetables	120	700	15

- c) Explain Bandhara irrigation scheme in detail. [6]

- Q6) a) Derive an expression for discharge from a well in unconfined aquifer the well fully penetrates it. [8]
- b) Briefly explain role of ground water in water resources development of country. [8]

SF-19
[6]

Q7) a) Explain in detail following:

- Intensity of irrigation
- Kor watering
- Kor depth
- Kor period
- Crop ratio
- Overlap allowance

- b) Explain estimation of evapo-transpiration by penman method. [5]
- c) Discuss in brief water logging and land drainage. [5]

- Q8) a) Explain need and importance of water shed management. [8]
- b) Explain with neat sketch the layout, main components and working of percolation tanks also explain its advantages and disadvantages. [8]

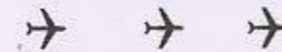

SF-22

Total No. of Pages : 3

Seat No.	
----------	--

T.E. (Civil) (Part - III) (Semester - V) (Revised)
Examination, November - 2017
TRANSPORTATION ENGINEERING - I
Sub. Code : 66239

Day and Date : Wednesday, 22 - 11 - 2017
Time : 10.00 a.m. to 1.00 p.m.

Total Marks : 100

- Instructions : 1) All questions are compulsory.
2) Figures to the right indicate full marks.

SECTION - I

Q1) a) Explain the classification of roads according to Lucknow Road Plan. [8]

b) Explain the factors controlling the highway alignment. [8]

OR

b) What do you understand by 'Stopping Sight Distance'? State the factors affecting Stopping Sight Distance. Calculate the SSD on a level road for design speed of 60 kmph for two-way traffic on a single lane road. Assume coefficient of friction 0.36 and reaction time of driver as 2.5 Seconds. [9]

Q2) a) What is the significance of 'Penetration Test on Bitumen'? Explain the procedure in detail. [8]

b) Explain functions of the components of a flexible pavement with sketch. [8]

OR

b) Explain 'CBR Test'. How the pavement thickness is determined by CBR method? [9]



SF-22

- Q3) a) What are the objects of conducting 'Traffic Volume Study'? Explain the methods of Traffic Volume Study. [8]
- b) Explain the steps of construction of Cement Concrete Pavements. [8]

OR

- b) State the necessity and methods of Highway Drainage. [8]

SECTION - II

- Q4) a) Explain movement of aeroplane about three axes with a neat sketch. [8]
- b) Explain with sketches, [8]
- i) Fillets,
 - ii) Holding Apron

OR

- b) Determine the length of runway required for following data, [9]
- Basic runway length under standard conditions = 1200m
- Site elevation above M.S.L. = 900 m
- Aerodrome reference temperature = 16°C
- Effective gradient = 0.5%

- Q5) a) Explain with sketches, [8]
- i) Wave action on a sea wall
 - ii) Littoral Drift
- b) Explain Dry Docks and Wet Docks. [8]

OR

- b) Explain the requirements of a harbour. State the factors to be considered while selecting a harbour. [8]

- Q6) a) Explain: [8]
- i) Lighting in tunnels;
 - ii) Ventilation in tunnels
- b) Explain 'Shield Method' of tunneling in soft ground with sketch. [8]

OR

- b) Explain the operations in sequence in one cycle of tunneling in hard rock. [9]



Seat No.	
----------	--

T.E. (Civil Engg.) (Part - II) (Semester - VI) (Revised)
Examination, November - 2017
ENGINEERING MANAGEMENT
Sub. Code: 66875

Day and Date : Friday, 03 - 11 - 2017
 Time : 2.30 p.m. to 5.30 p.m.

Total Marks : 100

- Instructions :
- 1) All questions are compulsory.
 - 2) Figures to right indicates full marks.
 - 3) Assume suitable data if necessary.

SECTION - I

- Q1) a) Enumerate principles of management given by Henry fayol and explain any three of them? [8]

OR

- a) With suitable example explain decision tree? [8]
- b) Four salesman are to be assigned to four district Estimates of sales revenue in thousands of rupees for each salesman is given below.

Assign salesman to the district.

[10]

Salesman	District			
	A	B	C	D
01	32	35	40	28
02	40	25	30	22
03	42	27	34	30
04	25	39	41	35

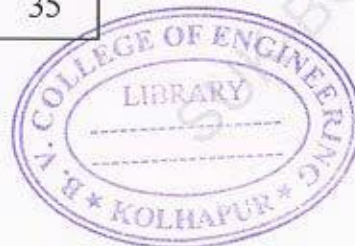

P.T.O.

- Q2) a) Enumerate types of organization? With neat organization structure diagram explain any one along with its advantages and disadvantages? [8]

OR

- a) Define planning? Explain process and characteristic of planning? [8]
 b) Calculate total cost of inventory & EOQ from following annual consumption of 36000 units, inventory carrying cost is 20% per annum with ordering cost 25 RS associated with one order & cost per item is 1 Rs? [8]

- Q3) Write any two [16]

- a) Derive derivation for EOQ formula.
 b) State and describe importance of management in construction industry.
 c) Explain ABC analysis concept with neat graph?

SECTION - II

- Q4) a) Suggest which equipment should be purchased if rate of interest is 12% per year by using present worth method.

	Equipment A	Equipment B
Initial Cost (Rs)	Rs 25000/-	Rs 35000/-
Annual O & M cost (Rs)	Rs 9000/-	Rs 7000/-
Salvage value (Rs)	Rs 2000/-	Rs 3500/-
Life (in Years)	5	5

[12]

- b) With suitable example explain the term equivalence. [6]

OR

- b) With suitable example explain the term time value of money. [6]

Q5) a) Draw a typical layout for site of construction of multistoried building. [5]

OR

- a) What do you know about child labour act? [5]
- b) What are the factors considered for site layout? [5]
- c) Write a detailed note on building and other construction workers act. [6]

Q6) Write Any 2 [16]

- a) Write down procedure for value analysis?
- b) Draw quality circle organization structure and explain benefits of quality circle?
- c) With neat flow chart describe the procedure of work study?



SF - 25

Total No. of Pages :3

Seat No.	
----------	--

T.E. (Civil) (Semester - VI) (New) Examination, November - 2017

ENGINEERING GEOLOGY

Sub. Code: 66876

Day and Date :Monday, 06 - 11- 2017

Total Marks : 100

Time :2.30 p.m. to 5.30 p.m.

- Instructions :
- 1) All questions are compulsory.
 - 2) Answer to the two sections must be written in one and same answer book.
 - 3) Figures to the right indicate full marks.

SECTION-I

Q1) Attempt any two of the following:

- a) Describe with neat sketches depositional features formed by river. [9]
- b) What is meant by Igneous Rock? Give the classification of Igneous Rocks on the basis of mode of occurrence. Mention one rock from each group. [9]
- c) What are the parameters of fault? Explain the causes of faulting. [9]

Q2) Attempt any two of the following:

- a) Explain in brief various process of weathering. [8]
- b) What is metamorphism? Describe in detail the agents of metamorphism. [8]
- c) Describe with the help of neat sketches the part of folds. Give in brief the Civil Engineering significance of fold. [8]



P.T.O.

Q3) Write short notes on:

- a) Interior of the Earth.
- b) Grain size classification of Sedimentary Rocks.
- c) Types of unconformity.
- d) Scope of Engineering Geology.

SECTION-II

Q4) Attempt any two of the following:

- a) Explain the various causes of earthquake. Write a brief note on RIS. [9]
- b) Describe the internal causes of landslides. [9]
- c) With a suitable sketch explain the zones of groundwater. [9]

Q5) Attempt any two of the following:

- a) Explain the various steps in the preliminary geological investigation at a civil engineering site. [8]
- b) Data obtained from a drill hole at foundation site is as follows. [8]
 - i) Top of borehole- R.L.410 m.
 - ii) Bottom of borehole- R.L. 380 m.
 - iii) Length of each piece of core obtained between 400m and 397m is, 16, 11, 13, 09, 08, 21, 23, 06, 05, 09, 08, 14, 19, 23, 21, 16, 18, 07, 06, 07, 10

Find,

- 1) Total length of core recovered
- 2) Core Recovery
- 3) Core loss
- 4) RQD

c) Explain the suitable and unsuitable conditions for excavating a tunnel. [8]

Q6) Write short notes on the following:

[16]

- a) Dams on Deccan Trap.
- b) Overbreak.
- c) Observations during drilling.
- d) Confined aquifer.

EEE

Mat	
No.	

S.E. (Civil) (Part - II) (Semester-IV)

Examination, November - 2017

FLUID MECHANICS - II

Sub. Code : 63347

Day and Date : Monday, 06-11-2017

Total Marks : 100

Time : 10.00 a.m. to 1.00 p.m.

- Instructions :
- 1) Question no. 1 and 5 are compulsory.
 - 2) Attempt any other two questions from each section.
 - 3) Assume any suitable data if necessary.
 - 4) Figures to the right indicate full marks.

SECTION-I

- Q1) a) Design an efficient trapezoidal channel of side slope 2H:1V bed slope 1 in 4900 to carry a discharge of $8\text{m}^3/\text{sec}$. Take Manning's $n=0.025$. [5]
- b) Define - Most economical channel section. Derive the formula for most efficient triangular section. [5]
- c) Derive an expression for the loss of energy due to hydraulic jump in a rectangular channel is in the form of [5]

$$\Delta E = \frac{(Y_2 - Y_1)^3}{4Y_1 Y_2}$$

- d) Compare Gradually Varied flow and Rapidly Varied Flow? [5]

- Q2) a) Draw the following [5]
- i) Specific energy curve.
 - ii) Specific force curve.
 - iii) Discharge diagram.
- b) A 3m wide rectangular channel carries a discharge of $1.85\text{m}^3/\text{sec}$ at a depth of 0.5m. Find the greatest allowable contraction in the width to get critical flow at the contracted section. [5]
- c) Derive Chezy's formula for uniform flow in an open channel. [5]

P.T.O.



Q3) a) Derive the expression

$$(dy/dx) = \frac{S_o - S_f}{1 - Fr^2}$$

Where (dy/dx) = Water surface slope

S_o = channel bottom slope

S_f = Energy line

Fr = Froude Number

[5]

- b) Discuss the relation between water surface slope and channel bottom slope. [5]
- c) Write a note on M_1 and M_3 curve. [5]

Q4) a) Derive the expression for hydraulic jump

$$\frac{Y_2}{Y_1} = \frac{1}{2} \left\{ -1 + \left(1 + 8 \left(\frac{Y_c}{Y_1} \right)^3 \right)^{1/2} \right\}$$

Where Y_1 = depth of water before jump

Y_2 = depth of water after jump

Y_c = critical depth.

[5]

- b) A rectangular channel 7.5m wide has a uniform depth of flow of 2.0m and has a bed slope of 1 in 3000. If due to weir constructed at the down stream end of the channel, water surface at a section is raised by 0.75m. Determine the water surface slope with respect to horizontal at this section. Assume Manning's $n = 0.02$. [5]
- c) A rectangular channel carries a discharge of $2\text{m}^3/\text{sec}$ per meter width. If the loss of energy in the hydraulic jump is found to be 2.75m, determine the conjugate depths before and after the jump. [5]

SECTION-II

- Q5) a) Discuss the advantages of Triangular weir over Rectangular weir. [5]
- b) Write a note on ventilation of weir. [5]
- c) What are advantages of hydro-electric power plant. [5]
- d) What are the different efficiencies of a centrifugal pump. [5]

- Q6) a) Derive an expression for the force exerted by the jet at centre on a stationary curved plate. [5]
- b) A 50mm diameter jet having a velocity of 25m/sec strikes a flat plate the normal of which is inclined at 30° to the axis of the jet. Calculate the normal force exerted on the plate. [5]
- i) When the plate is stationary.
- ii) When the plate is moving with a velocity of 10m/sec in the direction of the jet.
- c) In an experiment on a $90^\circ V$ notch, the flow is collected in a rectangular tank having the cross section $0.8 \times 0.8\text{m}$. If the water level in the collecting tank changed from 0.7m to 1.4m in 17.2 seconds when the head over the notch was 0.2m, estimate the coefficient of discharge for the notch. [5]

- Q7) a) Write short note on NPSH- centrifugal pump. [5]
- b) Define Static head, Manometric head, Delivery head, Gross head and suction head. [5]
- c) Write short note on common pump troubles. [5]
- Q8) a) What is hydraulic turbine? How are they classified? [5]
- b) What are disadvantages of hydroelectric power generation? [5]
- c) Draw the figure of Francis turbine. [5]

Seat No.	
----------	--

S.E. (Civil Engineering) (Semester-IV) (New)
Examination, November - 2017
CONCRETE TECHNOLOGY
Sub. Code :63346

Day and Date : Friday, 03- 11 - 2017
Time : 10.00 a.m. to 1.00 p.m.

Total Marks : 100

- Instructions :**
- 1) All questions are compulsory.
 - 2) Figures to right indicate full marks.
 - 3) Assume suitable data if necessary.

SECTION - I

- Q1) a)** Describe effect of impurities in water on properties of concrete. [8]
b) Describe the procedure for determining standard consistency of cement. [8]
- Q2) a)** Define placing of concrete and describe the different method of placing of concrete. [8]
b) Compare slump test and compacting factor test for determining the workability of concrete. [8]
- OR
- b)** What do you mean by mineral admixture? Explain in detail silica fume and GGBS? [8]
- Q3) a)** Enlist different tests for hardened concrete. Explain Split cylinder test. [9]
b) What is creep and shrinkage of concrete? List the factors affecting creep and shrinkage of concrete. [9]



P.T.O.

SECTION - II

24) Write short notes (any three)

[18]

- Ferrocement
- No-fines concrete
- Vacuum Dewatered Concrete
- Roller Compacted Concrete

25) a) What is durability of concrete? Enlist factors affecting durability of concrete. Explain any one in detail. [8]

b) What is permeability of concrete? Enlist factors affecting permeability of concrete. Explain any one in detail. [8]

OR

b) List various Non-Destructive tests for assessment of strength of concrete. Explain Rebound Hammer test. [8]

26) Define the "Mix design" and design concrete mix M20 using following data and IS: 10262 procedures. [16]

- Max. size of aggregate - 20 mm
- Degree of workability = 0.80 CF
- Degree of quality control = good
- Type of exposure = mild
- w/c = 0.47
- Cement used = OPC 53 grade
- Sp. Gravity of cement = 3.15, Coarse aggregate = 2.85, Fine aggregate = 2.65
- Water absorption of Coarse aggregate = 0.5%, Fine aggregate = 1.0%
- Free moisture in C.A. = 0.0%, F.A. = 0.0%
- Bulk density of Cement = 1440, C.A. = 1650, F.A. = 1800 kg/m³

Take standard deviation: 5 and Tolerance factor: 1.65

Table No. 2 Maximum Water Content per Cubic Meter of Concrete for Nominal Maximum Size of Aggregate

Sr.No.	Nominal Maximum Size of Aggregate	Maximum Water Content kg/m ³
1	10	208
2	20	189
3	40	165

Table No. 3 volume of Coarse Aggregate per Unit Volume of Total Aggregate for Different Zones of Fine Aggregate

Sr.No.	Nominal Size of Aggregate	Zone IV	Zone III	Zone II	Zone I
1	10	0.50	0.48	0.46	0.44
2	20	0.66	0.64	0.62	0.60
3	40	0.75	0.73	0.71	0.69

Sl. No.	Exposure	Plain Concrete		Reinforced Concrete			
		Minimum Cement Contents kg/m ³	Maximum Free W/C ratio	Minimum Grade of concrete	Minimum Cement Content kg/m ³	Maximum Free W/C ratio	Minimum Grade of Concrete
1.	Mild	220	0.60	-	300	0.55	M 20
2.	Moderate	240	0.60	M 15	300	0.50	M 25
3.	Severe	250	0.50	M 20	320	0.45	M 30
4.	Very Severe	260	0.45	M 20	340	0.45	M 35
5.	Extreme	280	0.40	M 25	360	0.40	M 40

★ ★ ★

Seat
No.

S.E. (Civil) (Semester - IV) (Revised)

Examination, November - 2017

SURVEYING - II

Sub. Code: 63345

Day and Date : Thursday, 02 - 11 - 2017

Total Marks : 100

Time : 10.00 a.m. to 1.00 p.m.

- Instructions :
- 1) Answer any THREE questions from Each section.
 - 2) Figures to the RIGHT indicate FULL marks
 - 3) Assume suitable data if NECESSARY and state them clearly.
 - 4) Answers shall be supported by adequate sketches.

SECTION-I

Q1) Attempt any three questions.

- a) Explain the theory of Stadia tacheometry in detail. [7]
- b) To find the RL of station C two observations are taken by a theodolite from station A. One to a BM and the other to the station C. The record as follows.

Inst. station	Staff station	Target	Vertical angle	Staff Reading	Remark
A	BM	Lower	-12°30'	0.565	RL of BM=755.5m
		Upper	-8°20'	2.565	
A	C	Lower	-7°30'	1.25	
		Upper	+3°12'	3.2	

Find RL of C and the distance between the BM and station C. BM and stations A,C are collinear. [10]

P.T.O.



SF - 15

- Q2) a) What are the factors considered for selection of base line? [4]
b) Explain the principle of EDM. [4]
c) Two triangulation stations A and B 60 km apart and have elevations 240 m and 280m respectively. Find minimum height of signal required at B so that line of sight may not pass near the ground than 2 meters. The intervening ground may be assumed to have uniform elevation of 200m. [9]

Q3) Write a short note any four. [16]

- a) Tacheometric contouring
b) Total station
c) Trilateration
d) Reconnaissance in triangulation
e) Triangulation figures.

Q4) a) What is spherical triangle? Discuss its properties. [5]

b) Define the following terms.

- i) Rational horizon
ii) Prime vertical
iii) Visible horizon [6]

c) Explain the significance of Polaris in field astronomy. [5]

SECTION-II

Q5) a) Derive an expression for calculating ordinates from long chord. [5]

b) Find out the necessary data for setting out a simple circular horizontal curve by the method of offsets from chords produced. Take peg interval as 20m., angle of intersection as 144° , radius of curve as 300m., chainage at point of intersection as 1390 m. [9]

c) What are the functions of a Transition curve. [3]

SF - 15

Q6) a) Draw a neat line diagram of mirror stereoscope and also explain the principle on which it works. [6]

b) Calculate the maximum number of photographs required to cover a fairly level area with the following data. Scale of photography is 1:10,000, Area is 100Sq.Km, Longitudinal overlap is 60% , Side lap is 30%, Size of photographs is 20 cm. \times 20 cm. [6]

c) Discuss the uses of Photogrammetry. [5]

Q7) a) Explain Electromagnetic energy and its interaction with matter. [8]

b) Describe in brief the segments of GPS. [5]

c) What are the advantages of GIS. [3]

Q8) Write short notes on. [16]

a) Vertical curves

b) Reverse curves

c) Fiducial marks and fiducial axes

d) Atmospheric windows.



Seat No.	
----------	--

S.E. (Civil) (Semester - IV) (Revised) Examination, November - 2017

STRUCTURAL MECHANICS

Sub. Code : 63344

Day and Date : Wednesday, 01 - 11 - 2017

Total Marks : 100

Time : 10.00 a.m. to 1.00 p.m.

- Instructions :
- 1) All questions are compulsory.
 - 2) Figures to the right indicate full marks.
 - 3) Use of electronic calculator is permitted.
 - 4) Assume suitable data if necessary and mention it clearly.

SECTION - I

- Q1) a) Derive the for normal and tangential stresses on a plane making angle θ with σ_x direction. [6]
- b) A thin cylinder with 1000 mm dia. and 20 mm wall thickness is subjected to internal pressure of 2 MPa. In addition the cylinder is subjected to shear stress of 30 MPa. Calculate the principal stresses and their orientation. [10]

- Q2) a) Derive the limiting value of eccentricity on rectangular section for no tension condition and show the kern of the section. [6]

OR

Discuss different modes of failure of gravity dam and their significance in analysis of dam.

- b) A trapezoidal masonry dam 4 m high is 1 m wide at top and 3 m wide at base retains water against vertical face. Determine max. and min. intensities of pressure. Unit weight of masonry = 20 kN/cum. [10]

- Q3) Attempt any two : [2 × 9 = 18]

- a) Construct the influence line diagrams for force in members U_1U_2 , L_1L_2 , L_2U_3 and U_1L_1 of the through truss shown in fig. 1

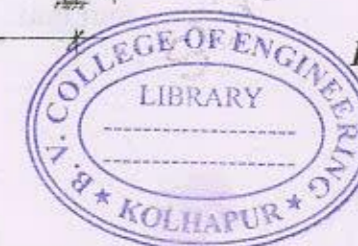
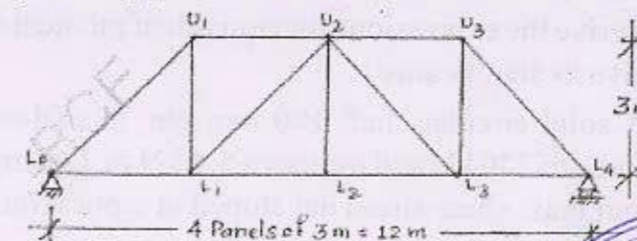

P.T.O.

- b) Construct the influence line diagrams for reaction at A and moment at A of the compound beam shown in fig. 2.

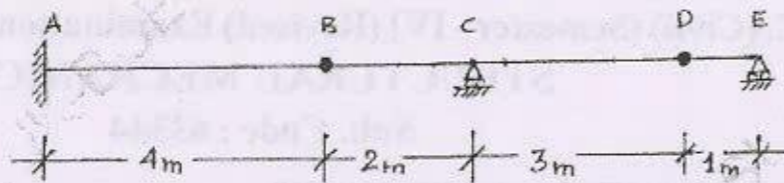

- c) Using the I.L.D.s of Q.3 (b) find the values R_A and M_A when load of 100 kN acts at D.

SECTION - II

- 24) a) State the conjugate beam theorems with neat diagrams and draw the conjugate beams for the beams shown in the fig.3. [6]

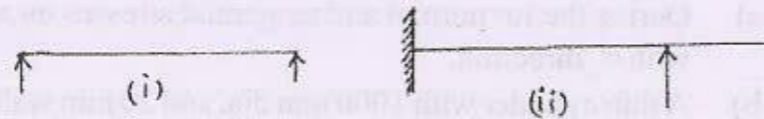

OR

Using double integration method find the central deflection of the simply supported beam subjected to u.d.l. on entire span.

- b) Find the slope and deflection at end C of the beam shown in fig. 4. [10]

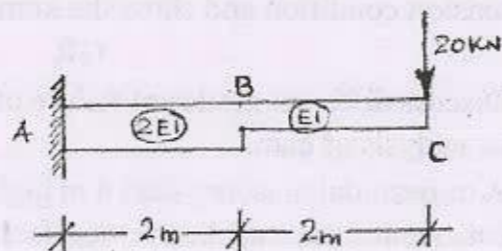

- 25) Attempt any two :

[2 × 9 = 18]

- The maximum allowable shear stress in a hollow shaft whose outer dia. is twice the inner dia. is 80 MPa. Determine the diameter of the shaft if it is subjected to torque of 4 kN.m. and bending moment of 3kN.m.
- Derive the expressions for equivalent moment and equivalent torque and give its significance.
- A solid circular shaft 100 mm dia. is subjected to axial compressive force of 240 kN and torque of 5.4 kN.m. Determine the principal stresses and max. shear stress developed at a point on the surface of the shaft.

- 26) a) State the assumptions and limitations of the Euler's formula. [5]

- b) The member of a frame of machine acts as strut with both ends fixed. The cross section of the member is formed of two tubes and a plate welded as shown in fig.5. The length of the member is 1.5 m. Taking factor of safety = 6 find the maximum load the member can resist. Take $f_y = 320 \text{ N/mm}^2$, $\alpha = 1/7500$. [11]

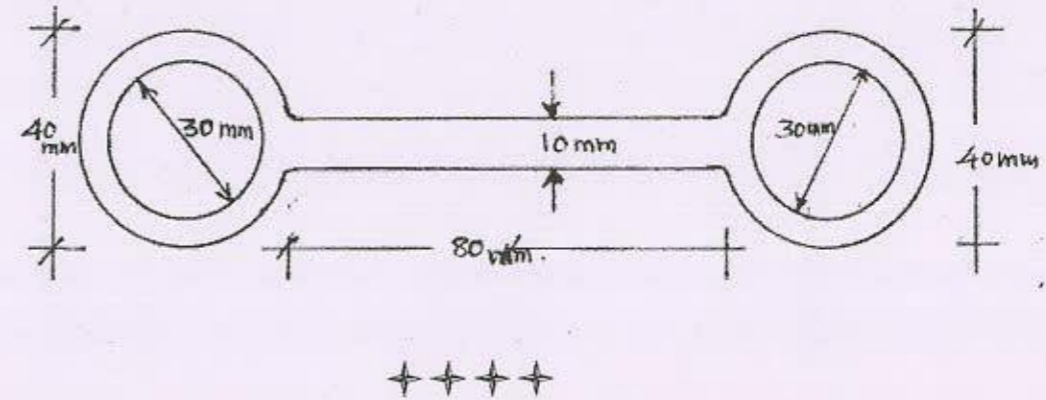

SF - 12
[18]

Q8) Write short notes on any three of following:

- Concept of HGL and TEL with illustrative sketches.
- Use of Moody's chart.
- Boundary layer: concept, separation and control.
- Water hammer and surge tank.



SF - 12
Total No. of Pages :4

Seat No.

S.E. (Civil) (Semester - III) Examination, November - 2017
FLUID MECHANICS - I
Sub. Code: 63341

Day and Date : Tuesday, 21 - 11 - 2017
Time : 10.00 a.m. to 1.00 p.m.

Total Marks : 100

- Instructions :
- Attempt any three questions from each section.
 - Figures to the right indicate full marks.

SECTION - I

- Q1) a) Define and explain significance of following fluid properties with their SI units. [8]
- Viscosity.
 - Bulk modulus of elasticity.
 - Vapor pressure.
 - Surface tension and Capillarity.
- Give practical examples.
- b) Find the form of equation for discharge Q through a sharp edged triangular notch, which depends on central angle α of notch, head H , acceleration due to gravity g , density ρ , viscosity μ and surface tension σ . Use Buckingham π theorem of dimensional analysis. [8]
- Q2) a) Explain how to calculate total pressure acting on a curved surface immersed in liquid. [4]
- b) Find total pressure acting on unit length of a dam with vertical upstream face for a depth of water 50 m out of which bottom 10m is silt of specific gravity 1.2. Draw a sketch to show pressure diagram. [6]



P.T.O.

- c) A wooden cylinder of circular section and uniform density, specific gravity 0.6 is required to float in oil of specific gravity 0.8. If the diameter of the circular is d and its length is '1' can not exceed about $0.817d$ for cylinder to float with its longitudinal axis vertical. [6]

- Q3) a) What is flownet? What are methods of drawing flownet? Give the uses of flownet and its limitations. [6]
- b) Define stream function and velocity potential function.

The velocity components in a 2 dimensional flow field for an incompressible fluid are expressed as [6]

$$u = y^3/3 + 2x - x^2y$$

$$v = xy^2 - 2y - x^3/3$$

Obtain an expression for stream function ψ

- c) Two velocity components are given in the following case, find the third component such that they satisfy the continuity equation. [4]

$$u = x^3 + y^2 + 2y^2$$

$$v = -x^2y - yz - xy$$

- Q4) Write short note on any three of following : [18]

- Dimensionless numbers and their significance in model studies.
- Stability of submerged and floating bodies.
- Types of flow in pipe with practical examples.
- Pressure measurement devices.

SECTION - II

- Q5) a) Derive Euler's equation of motion along a stream line and further derive Bernoulli's theorem. What are the limitations. [8]
- b) A venturimeter is to be fitted in a pipe of 0.25 m diameter where the pressure head is 7.6 m of flowing liquid and the maximum flow is $8.1 \text{ m}^3/\text{min}$. Find the least diameter of throat to ensure that the pressure head does not become negative. Take $C_d = 0.96$ [4]
- c) Derive the expression for time required to empty the tank through an orifice. [4]
- Q6) a) Explain Reynold's experiment. [6]
- b) Oil of viscosity 0.1 Pa.s and specific gravity 0.90, flows through a horizontal pipe of 25 mm diameter. If the pressure drop per meter length of the is 12 KPa. Determine,
- The rate of flow in N/min.
 - The shear stress at the pipe wall.
 - The Reynold's number of the flow
 - The power required per 50 m length of pipe to maintain the flow. [6]
- c) What do you mean by hydraulically smooth and rough boundaries. [4]
- Q7) a) What are the different losses in pipe flow? Derive expression for each loss. [8]
- b) A pipe 50 mm diameter is 6 m long and the velocity of flow of water in the pipe is 2.4 m/s. What loss of head and the corresponding power would be saved if the central 2 m length of pipe was replaced by 75 mm diameter pipe, the change of section being sudden? Take $f = 0.04$ for the pipes of both diameter. [8]

Seat No.	
----------	--

SE (Civil) (Part - II) (Semester - III) Examination, November - 2017
STRENGTH OF MATERIALS - I (Revised)

Sub. Code : 63340

Day and Date : Wednesday, 15 - 11 - 2017

Total Marks : 100

Time : 10.00 a.m. to 01.00 p.m.

- Instructions :
- 1) All questions are compulsory.
 - 2) Figures to the right indicate full marks.
 - 3) Use of non - programmable calculator is allowed.
 - 4) Assume any suitable data if required and state it clearly.

SECTION - I

- Q1) a) Explain with neat diagram, Stress-Strain Curve of mild steel rod under axial tensile force. [4]
- b) The rod ABC is made of an aluminum for which $E = 70 \text{ GPa}$ as shown in Fig. 1. Knowing that $P = 6 \text{ kN}$ up at point A and $Q = 42 \text{ kN}$ down at point B , determine the deflections at point A and point B . $AB = 0.4 \text{ m}$ and 20 mm dia, $BC = 0.5 \text{ m}$ and 60 mm dia. [13]

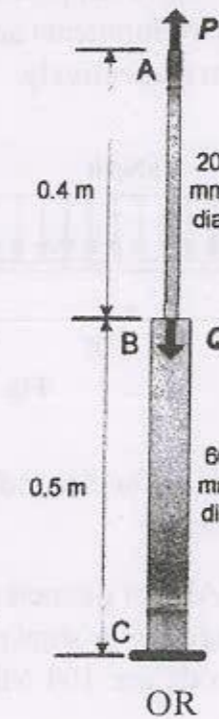

Fig. 1

OR

- a) Explain Saint-Venant's principle with neat diagrams [4]



P.T.O.

- b) At room temperature (21° C) a 0.5 mm gap exists between the ends of aluminum and steel rods of lengths 300 mm and 250 mm respectively as shown in Fig. 2. When temperature is reached 160°C, determine normal stress in aluminum bar and change in length of aluminum bar. [13]

Aluminum rod: Area = 1806 sq.mm, $E_A = 72$ GPa, $\alpha_A = 23.9 \times 10^{-6}/^\circ\text{C}$.
 Steel rod: Area = 774 sq.mm, $E_s = 190$ GPa, $\alpha_s = 17.3 \times 10^{-6}/^\circ\text{C}$

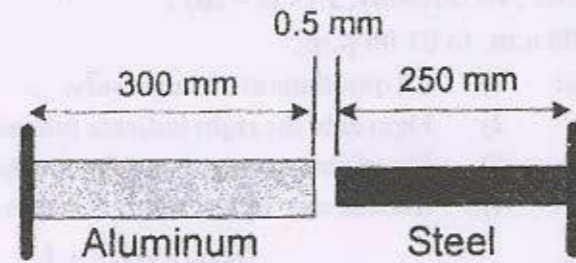

Fig. 2

- 22) a) Explain with neat diagrams, relationship between load, shear force and bending moment. [4]
 b) Draw Shear Force Diagram (SFD) and Bending Moment Diagram (BMD) for a cantilever beam ABC of length 3 m, fixed at A and free at C as shown in Fig. 3. AB (2 m) portion is loaded with uniformly distributed load of 1 kN/m, two moments are applied at B and C with magnitude 2 kN.m and 3 kN.m respectively. [13]

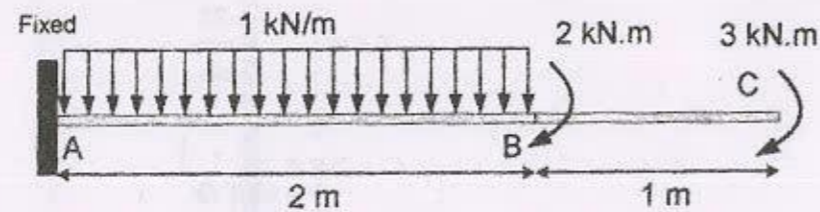

Fig. 3

- 23) a) Derive an expression for circumferential stress and longitudinal stress in thin walled cylinders. [4]
 b) Two rods, steel (AB) of diameter 38 mm and brass (BC) of diameter 46 mm connected together as shown in Fig. 4. If allowable shear stresses in steel and brass rods are 104 MPa and 55 MPa, find largest torque T applied at A. [12]

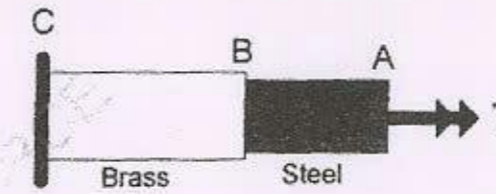

Fig. 4

SECTION - II

- 24) a) A beam 80 mm × 120 mm is 4 m long simply supported at its ends. The beam supports a central load W at the center of span of beam. If the maximum bending stress is limited to 4000 N/sq.cm. Find the value of W when. [9]
 i) Smaller dimension is used as depth
 ii) Greater dimension is used as depth.
 b) A cantilever beam of span 3 m carries uniformly distributed load of 2 kN/m. If the beam is of rectangular cross section, whose depth is twice the width of section, find width and depth of the beam. Allowable bending stress is 14000 N/sq.cm. [8]
- 25) a) Draw shear stress distribution diagrams for I and T sections with maximum and average values. [4]
 b) T sectional steel beam having flange of 100 mm × 20 mm and web 10 mm × 150 mm. Draw shear stress distribution across the depth of the section. If the beam is simply supported over a span of 5 m subjected to uniformly distributed load of 40 kN/m over entire span. [13]
- 26) A weight of 25 kN falls through 40 mm on a collar rigidly attached to the lower end of vertical steel bar of length 3.5 m and having area of 6.5 cm². What is the instantaneous maximum stress and corresponding instantaneous maximum strain of the bar. Take $E_s = 200$ GPa [16]



Seat No.	
----------	--

S.E. (Civil) (Semester - III)
Examination, November - 2017
SURVEYING - I
Sub. Code : 63339

Day and Date : Monday, 13-11-2017
Time : 10.00 a.m. to 1.00 p.m.

Total Marks : 100

- Instructions :**
- 1) Answer any THREE questions from EACH section.
 - 2) Figures to the RIGHT indicate FULL marks.
 - 3) Assume suitable data if NECESSARY and state them clearly.
 - 4) Answers shall be supported by adequate sketches.

SECTION - I

Q1) Solve (6 marks each) [18]

- a) Explain test and adjustment for setting the bubble axis parallel to line of collimation for dumpy level.
- b) Explain auto level with diagram of tilt compensator.
- c) Derive expression for correction for curvature and refraction.

Q2) a) State and explain significance of temporary and permanent adjustments for a Level. [8]

b) While carrying out two peg test following data are collected for a level [8]

Distance AB= 100 m

Instrument at C, 50 m i.e. midway between A&B

Reading at A = 2.5 m reading at B = 3.5 m

Instrument at D in line AB 25 m from B such that AD= 125 m

Reading at A= 2.0 m reading at B = 3.25 m

If the instrument is to be adjusted what procedure will you follow?

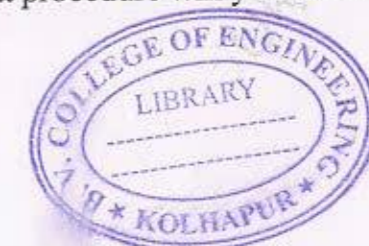

P.T.O.

SF-11

- 13) a) The perpendicular offsets taken at 10m interval from a survey line to an irregular boundary are 2.25, 3.85, 4.5, 6.8, 5.2, 7.35, 8.9, 8.3, & 5.45 m. determine the enclosed area by [8]
- Average ordinate rule
 - Trapezoidal rule
 - Simpson's rule.
- b) Define area of zero circle and methods for calculating area of zero circle. Explain any one method in detail. [8]

- 14) Write short notes on [16]
- Resectioning in plane table survey.
 - Plane table and its accessories.
 - Block contouring.
 - Factors affecting sensitivity of level tube.

SECTION - II

- 15) a) What is the purpose of [16]
- Making face left and face right observations.
 - Observing the readings on both the verniers.
 - Repetition method of horizontal angle measurement.
- b) Explain stepwise procedure of measuring horizontal angle by reiteration method. Also indicate under what circumstances it is preferred. [6]
- c) Name the fundamental lines of a transit theodolite and also indicate their inter-relationships. [5]

SF-11

- 16) a) From the following observations on the traverse ABCD, calculate the length and bearing of the line AB. [9]

Line	CA	CD	DB
Length in m.	66.25	330.20	150.00
Bearing	250°45'	15° 20'	270° 15'

- b) Explain stepwise procedure for carrying out theodolite traversing. Also, explain the sequential procedure of obtaining total co-ordinates from Gale's traverse table. [8]

- 17) a) What are Ranges? Name different types of Ranges and their significance. [5]
- b) Explain how leveling work is carried out in tunnel surveying. [5]
- c) Explain the construction and use of Nautical sextant. [7]

- 18) a) Explain by deriving necessary expressions the Double plane method to determine the reduced level of tip of an elevated tower. [8]
- b) Calculate the length of CD and bearing of the line AB from the following traverse observations. [8]

Line	AB	BC	CD	DA
Bearings	Roughly East	178°0'	270° 0'	1° 0'
Length in m.	150.00	75.50	Not obtained	63.00



SF-10
[16]

Q6) Attempt any two of the following:

a) Evaluate $\int_0^{1+i} (x^2 - iy) dz$ along the path

i) $y = x$

ii) $y = x^2$

b) Prove that $u = x^2 - y^2$ and $v = \frac{y}{x^2 + y^2}$ are harmonic functions of (x, y) but are not harmonic conjugates.

c) If $f(z) = u + iv$ is an analytic function of $z = x + iy$ and $u - v = e^{-x} [(x - y) \sin y - (x + y) \cos y]$ find $f(z)$

SF-10

Total No. of Pages : 4

Seat No.

S.E. (Civil Engg.) (Semester - III)
Examination, November - 2017
ENGINEERING MATHEMATICS - III
Sub. Code : 63338

Day and Date : Friday, 10 - 11 - 2017

Total Marks : 100

Time : 10.00 a.m. to 1.00 p.m.

- Instructions :
- 1) All questions are compulsory.
 - 2) Figures to the right indicate full marks.
 - 3) Use of Calculator is allowed.

SECTION - I

Q1) Solve any three of the following.

[18]

a) $(D^2 - D + 1)y = \cos 2x$

b) $(D^2 + 1)y = x^2 \sin 2x$

c) $(D^2 + 3D + 2)y = e^{e^x}$

d) The differential equation satisfied by a beam uniformly loaded with one end fixed and second subjected to a tensile force P is given by

$$EI \frac{d^2 y}{dx^2} = Py - \frac{1}{2} Wx^2$$

Show that elastic curve for the beam under conditions $y = 0, \frac{dy}{dx} = 0$

at $x = 0$ is given by $y = \frac{W}{Pn^2} (1 - \cosh nx) + \frac{Wx^2}{2P}$ where $n^2 = \frac{P}{EI}$.

Q2) Attempt any two of the following.

[16]

a) Find the directional derivative of $\phi = x^4 + y^4 + z^4$ at the point A(1, -2, 1) in the direction of AB where B is (2, 6, -1). Also find the unit vector normal to the surface $2x^2 + 4yz - 5z^2 = -10$ at (3, -1, 2).

P.T.O.



- b) A vector field \vec{F} is given by $\vec{F} = (x^2 - yz)\mathbf{i} + (y^2 - zx)\mathbf{j} + (z^2 - xy)\mathbf{k}$.

Show that \vec{F} is irrotational and find its scalar potential. Also find Grad (div \vec{F})

- c) If \vec{a} is a constant vector and $\vec{r} = xi + yj + zk$ then prove that

i) $\nabla(\vec{a} \cdot \vec{r}) = \vec{a}$

ii) $\text{div}(\vec{a} \times \vec{r}) = 0$

iii) $\text{div}(\vec{a} \cdot \vec{r}) \cdot \vec{a} = a^2$

iv) $\text{curl}(\vec{a} \times \vec{r}) = 2\vec{a}$

Q3) Attempt any two of the following.

[16]

- a) Fit a first degree curve to the following data and estimate the value of y when $x = 73$

x : 10 20 30 40 50 60 70 80

y : 1 3 5 10 6 4 2 1

- b) For the following data fit a curve of the form $y = ax^b$

x = 1 2 3 4 5 6

y = 1200 900 600 200 110 50

- c) From the following data find the line of regression of y on x and of x on y

x = 62 64 65 69 70 71 72 74

y = 126 125 139 145 165 152 180 208

SECTION - II

Q4) Attempt any two of the following:

[16]

- a) Seven coins are tossed and the number of heads obtained is noted. The experiment is repeated 128 times and the following distribution is obtained.

No. of heads	0	1	2	3	4	5	6	7
Frequency	7	6	19	35	30	23	7	1

Fit a binomial distribution if (i) the coins are unbiased (ii) the nature of coins is not known.

- b) A firm produces articles of which 0.1 percent are defective. It packs them in cases each containing 500 articles. If a wholesaler purchases 100 such cases, how many cases can be free from defectives, how many can be expected to have one defective.
- c) In a sample of 1000 students, the mean marks of a certain test is 14 and standard deviation is 2.5. Assuming the distribution to be normal, find
- how many students score between 12 and 15 marks?
 - how many students score above 18 marks?
 - how many students score below 8 marks?
 - how many students score 16 marks?

(Given: For S.N.V.Z area between $Z=0$ to 0.4 is 0.1554, area between $Z=0$ to $Z = 0.6$ is 0.2257, area between $Z=0$ to $Z = 0.8$ is 0.2881, area between $Z=0$ to $Z=1$ is 0.3413, area between $Z=0$ to $Z= 1.6$ is 0.4452, area between $Z=0$ to $Z=2.4$ is 0.4918)

Q5) Attempt any three of the following.

[18]

- a) Find the Laplace transform of $\frac{\sin t \sin 5t}{t}$
- b) Find the Laplace transform of $e^{-3t} \int_0^t u \sin 3u du$
- c) Find the inverse Laplace transform of $\frac{s}{(s^2 + 1)(s^2 + 4)}$ using convolution theorem.
- d) Use Laplace transform to solve $(D^2 + 4D + 13)y = e^{-t} \sin t$ where $y(0) = 0$ and $y'(0) = 0$.

SF-13

Total No. of Pages : 2

Seat No.	
----------	--

S.E. (Civil) (Part - II) (Semester - III) (Revised)
Examination, November - 2017
BUILDING CONSTRUCTIONS & MATERIALS
Sub. Code : 63342

Day and Date : Thursday, 23 - 11 - 2017

Total Marks : 100

Time : 9.30 a.m. to 1.30 p.m.

- Instructions :
- 1) All questions are compulsory.
 - 2) Figures to the right indicate full marks.
 - 3) Use of electronic calculator is permitted.
 - 4) Assume suitable data if necessary and mention it clearly.

SECTION - I

- Q1) a) Classification of bricks according to IS standards? Also state water absorption and crushing strength limit for the same? [8]
- b) Draw Cross section through external framed structure wall showing all components in sub structure mentioning their functional consideration. [8]
- Q2) a) Draw a neat sketch of one and one and half brick thick Flemish Bond masonry. [10]
- i) Plan of Odd and Even Course.
 - ii) Elevation for at least six courses.
- b) State various types of material used for partition wall. [6]
- Q3) Write short notes on any three : [18]
- a) Door fixtures and fastening.
 - b) Lift.
 - c) Construction of Wall strip Foundation.
 - d) Rat trap bond.
 - e) Arches and their stability consideration.



P.T.O.

SECTION - II

Q4) Design and draw quarter turn staircase to a scale of 1 : 20 the plan and sectional elevation for following data [25]

- a) Storey height : 3.20 m
- b) Staircase internal size 4.8×5.8 m
- c) Assume data wherever necessary.

Q5) Draw to a scale of 1 : 20 a sectional plan, side view and elevation for T.W. Paneled window for following data. [25]

- a) Clear opening : $1.5 \text{ m} \times 1.2 \text{ m}$
- b) Frame : $125 \text{ mm} \times 75 \text{ mm}$
- c) End Style and meeting style : $120 \text{ mm} \times 40 \text{ mm}$
- d) Rails : $120 \text{ mm} \times 40 \text{ mm}$
- e) Panel material : partly glazed partly teak wood
- f) Panel thickness : 20 mm
- g) Glass : 4 mm thickness
- h) No of shutter : 2 nos
- i) No of panel : 4 nos
- j) Shows various window fixtures and fastening.

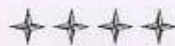

Seat No.	
----------	--

S.E. (Civil) (Part - II) (Semester - IV) (Revised)
Examination, November - 2017
BUILDING DESIGN AND DRAWING
Sub. Code: 63348

Day and Date : Tuesday, 07 - 11 - 2017
 Time : 9.30 a.m. to 1.30 p.m.

Total Marks : 100

- Instructions :
- 1) All questions are compulsory.
 - 2) Figures to the right indicate full marks.
 - 3) Assume suitable data if required and clearly mention it.

SECTION - I

- Q1) a) Explain the concept of F.S.I. [5]
 b) Explain : Site Plan. [5]

OR

- b) Write short note on 'Circulation' principle of a building planning. [5]
 Q2) Plan a bungalow (G+1) on the given plot. The requirements are as below,

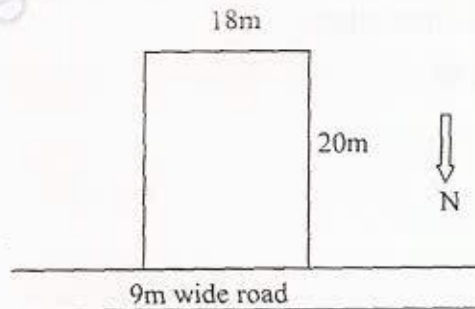

Name of Room	Tentative Size
Living Room	4 m X 5 m
Children Bed Room	5 m X 3.5 m
Master Bed Room	3.5 m X 4.5 m
Guest Bed Room	3 m X 4 m
Verandah	2.5 X 3 m
Store	1.3 X 2.5 m
Staircase	Suitable Size

Assume any other suitable data.

External walls - 230 mm thick. Internal walls - 150 mm thick.

P.T.O.



Draw to a suitable scale the following:

- i) Building Plans (Ground and First Floor) [25]
- ii) Furniture layout of Living Room [5]

Q3) Write short notes on any *two*: [10]

- a) Aspect
- b) Building Permission
- c) Maintenance of building
- d) Green building

SECTION - II

Q4) a) Explain the systems of plumbing with sketches. [10]

b) Explain : Intercepting Trap [6]

OR

b) Explain the types of wiring system. [6]

Q5) a) Explain the systems of ventilation with help of sketches. [10]

b) Explain the concept of thermal insulation. [6]

OR

b) Explain : Acoustics [6]

Q6) Write short notes on any *three*: [18]

- a) Types of Pointing.
- b) Characteristics of good paint.
- c) Summer air conditioning.
- d) Rain water harvesting.
- e) Fire resisting building materials.

