

**Mechanical Working Drawing question bank for unit test-2
(22341)**

Unit Test -II

TOPIC -4 PRODUCTION DRAWING

1. Write the definitions of terminologies used in limits and fits.
2. Define Allowance, Clearance, Interference and Deviation.
3. Problems related to maximum and minimum allowances.
4. What is fit and its classification?
5. Problems related to the calculation of type of fit?
6. List out the number of symbols used in geometrical characteristics control.
7. Draw conventional representation of general welding symbols.
8. Problems related to the welded parts.
9. Write different characteristics of surface roughness.
10. Write down the indication of machining symbols with all parameters.

CHAPTER -5 DETAILS TO ASSEMBLY DRAWING

Figure 5. Shows the details of universal coupling. Draw the following views of the assembly. (a) front view sectional (b) top view outside (c) prepare bill of material

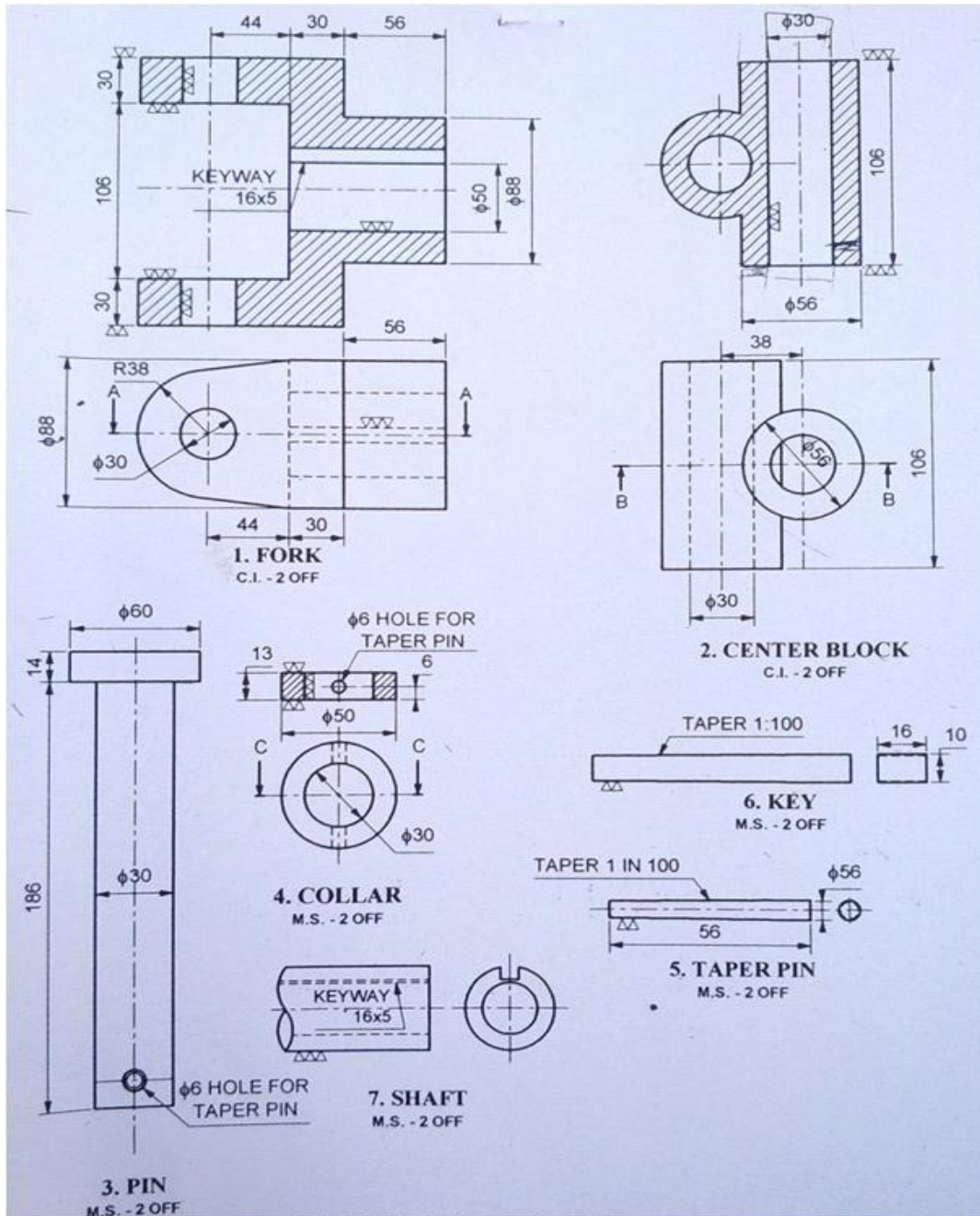
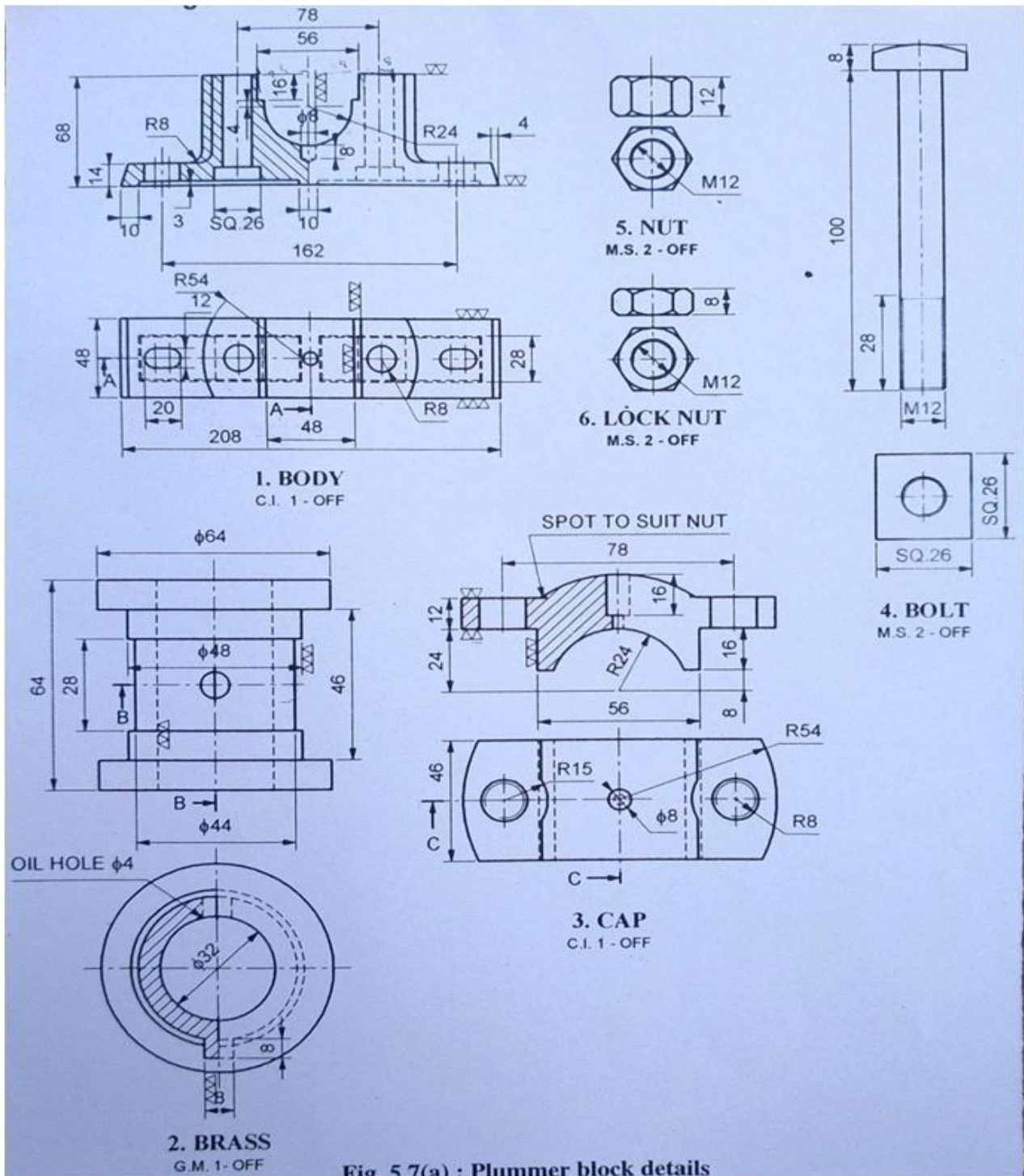

Figure 6. Shows the details of pedestal bearing plumber block. Draw the following views of the assembly. a) front view sectional b) top view outside c) prepare bill of material



3. Figure 7. Shows the details of machine vice. Draw the following views of the assembly. (a) front view sectional (b) top view outside
(c) prepare bill of material

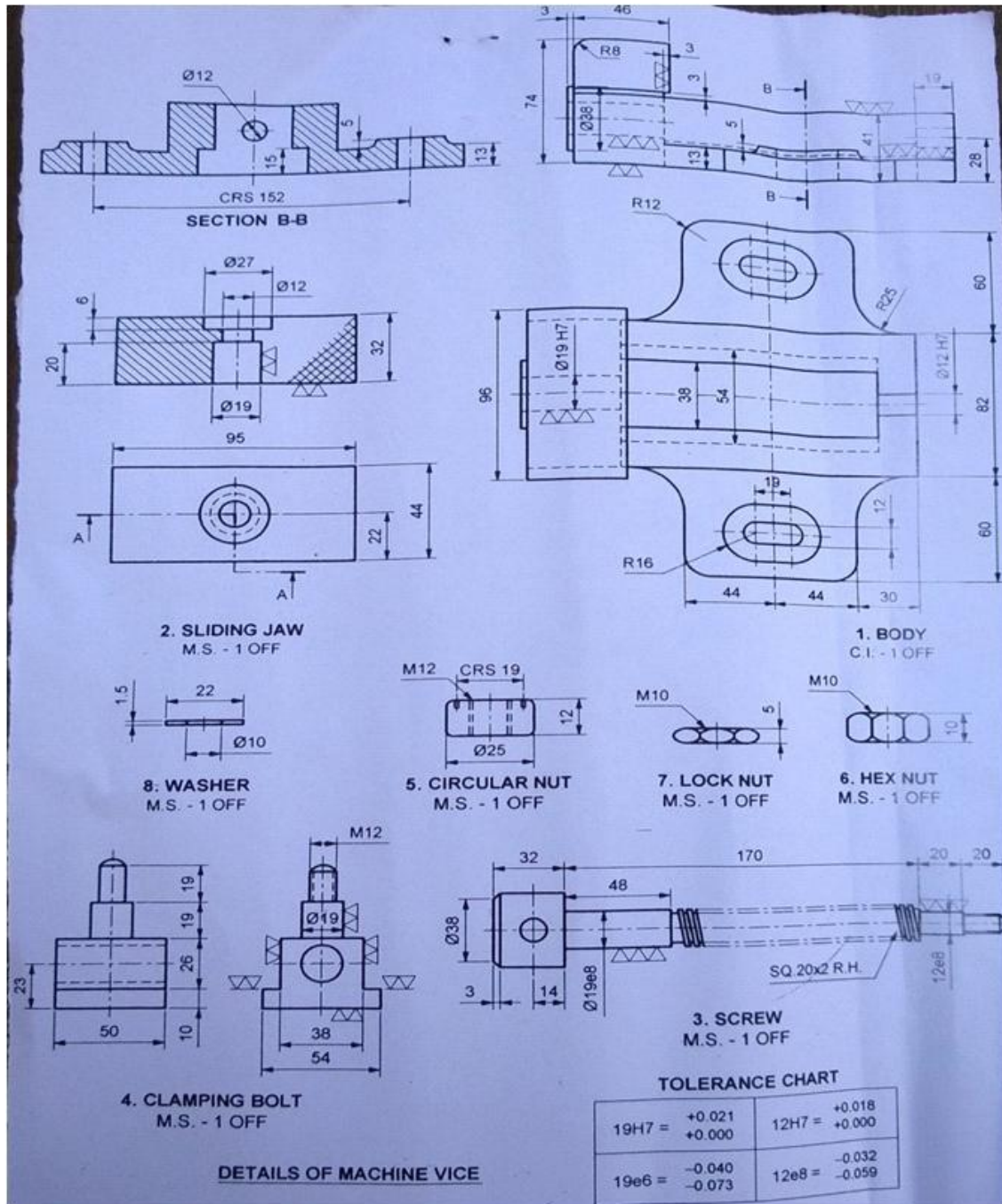
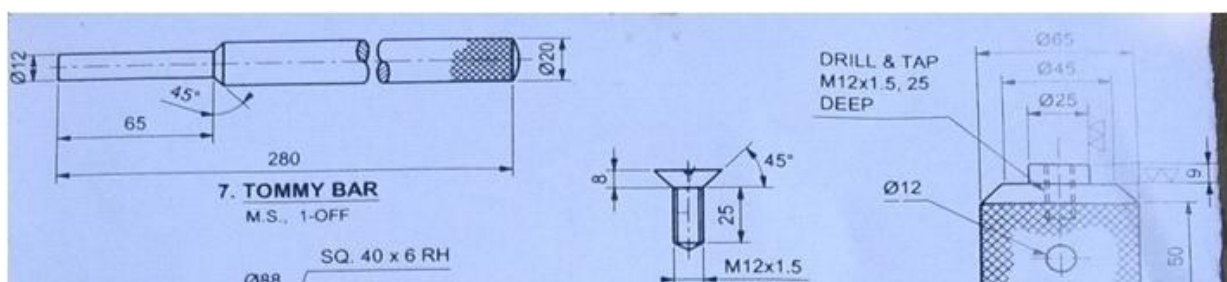

Figure 8. Shows the details screw jack. Draw the following views of the assembly. (a) front view sectional (b) top view outside (c) prepare bill of material.



CHAPTER -6
ASSEMBLY DRAWING TO DETAILS OF THE ASSEMBLY DRAWING

1. Figure 9. Shows the assembly of the tail stock. Draw the following details:

- (a) Body sectional FV.
- (b) barrel.
- (c) hand wheel (two views).
- (d) spindle bearing (two views)

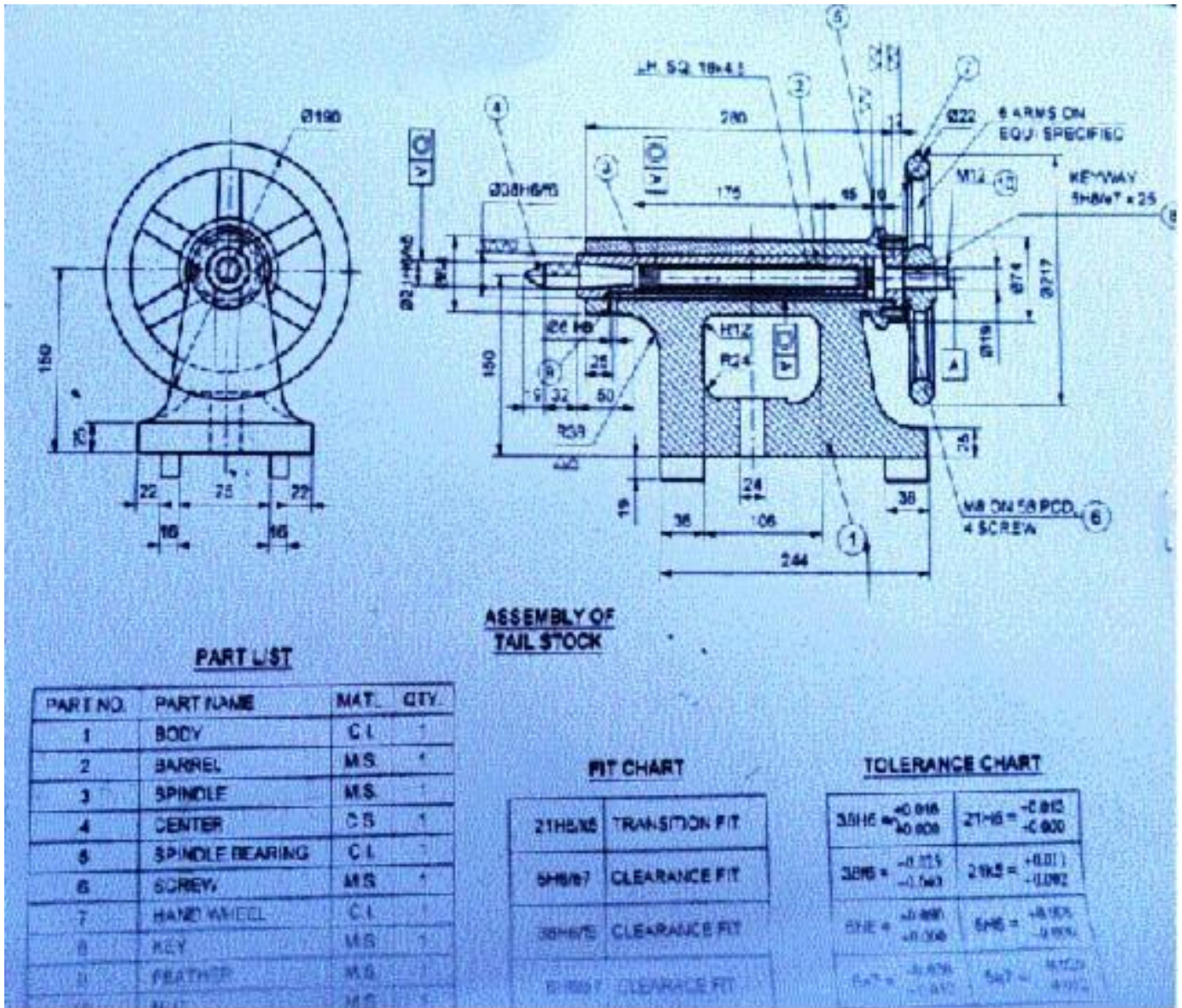

2. Figure 10. Shows the assembly of drilling jig. Draw the following details:
- (a) Body sectional FV (two views).
 - (b) Component (two views).
 - (c) plate.
 - (d) Also show type of fit used.

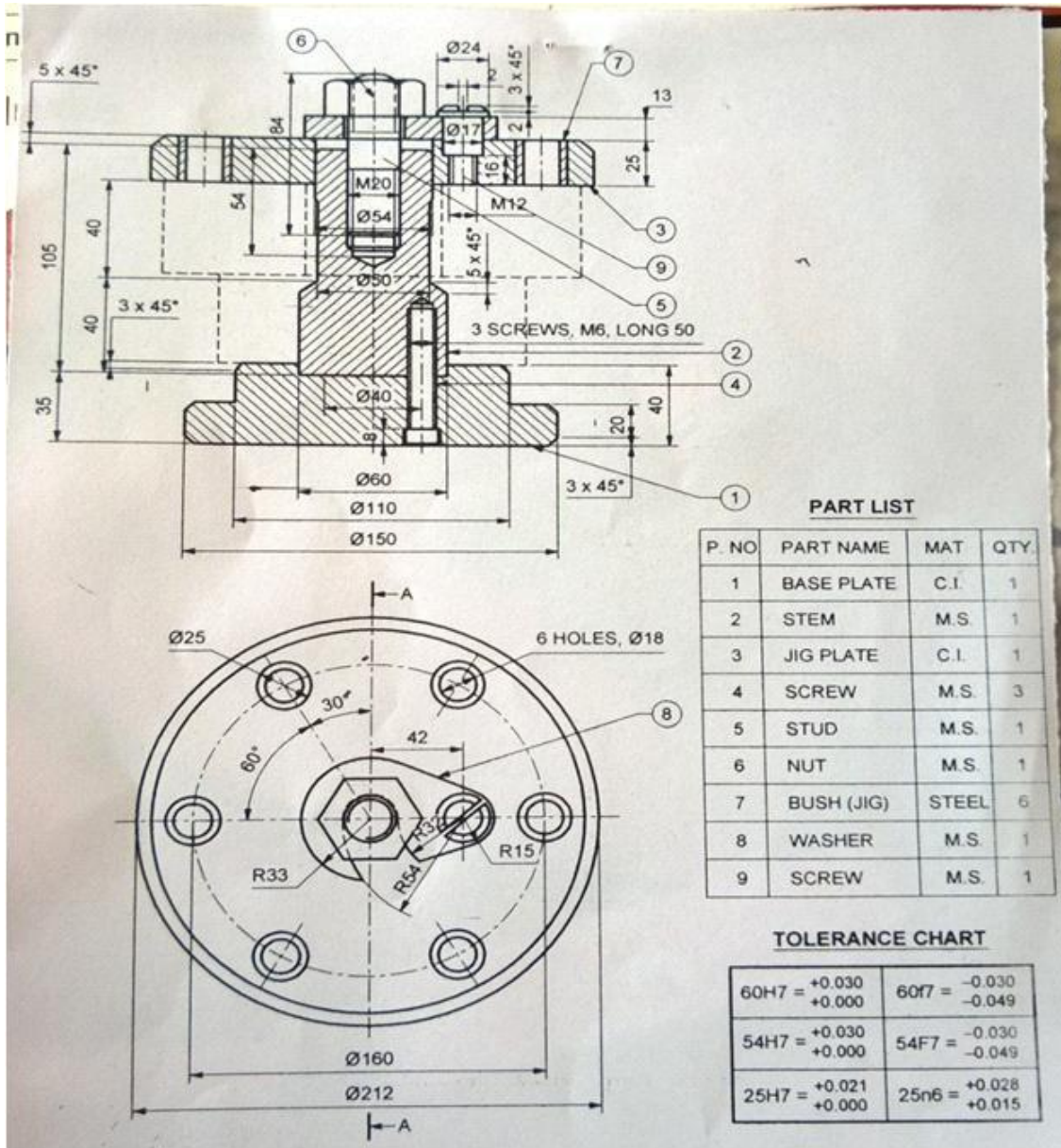
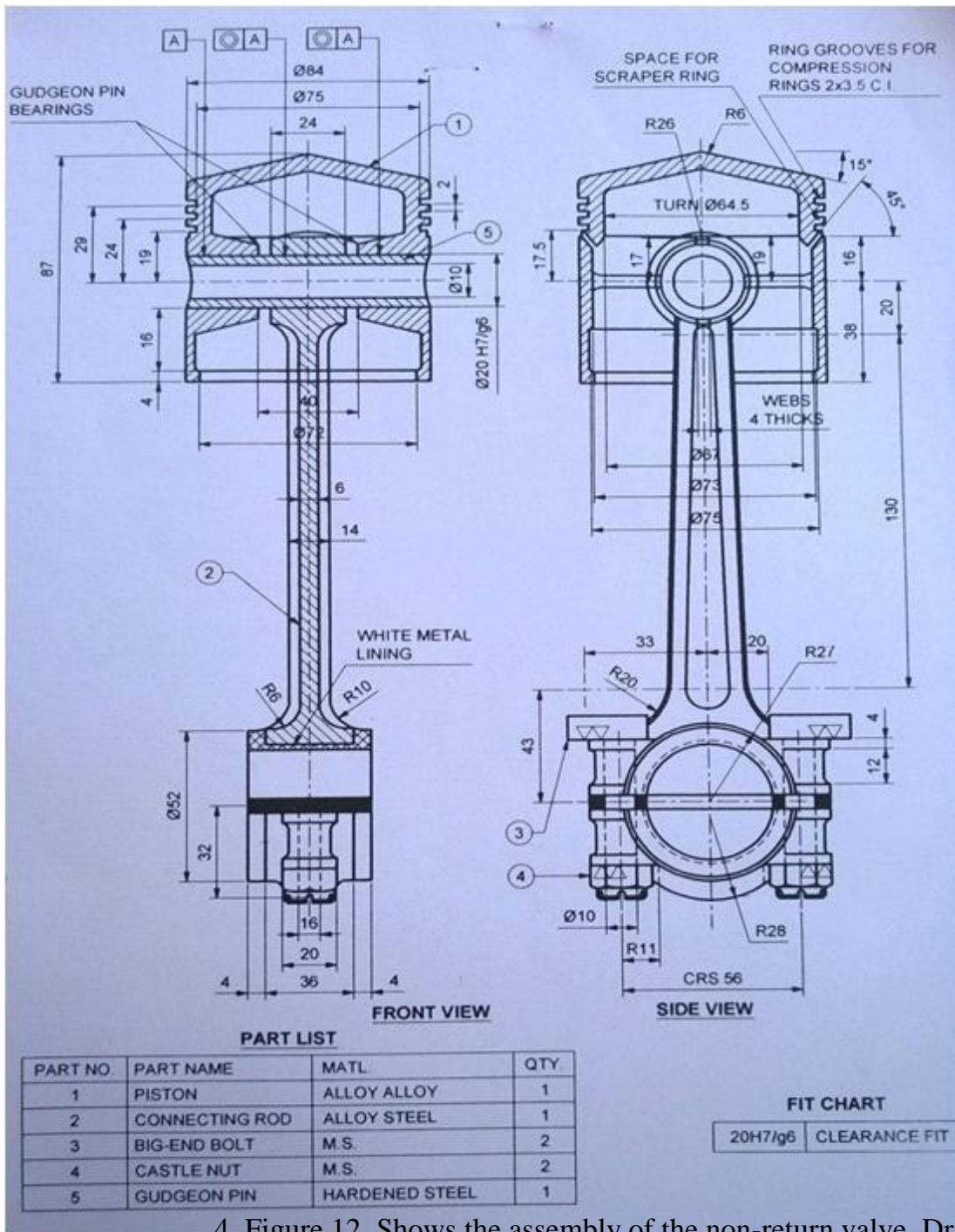

Figure 11. Shows the sectional front view, top view and sectional side view of an assembly of the piston and

connecting rod. Draw the part drawings of the components.



4. Figure 12. Shows the assembly of the non-return valve. Draw the following details:

- (a) Body sectional FV.
- (b) Cover.

(c) Valve seat

(d) Valve.

